

Year 4

For more sats papers go to [satspapers.org](http://satspapers.org)

### Using and applying mathematics

- Solve one- and two-step problems involving numbers, money or measures, including time; choose and carry out appropriate calculations, using calculator methods where appropriate

I pay three pounds sixty pence for a rail ticket. How much change should I get from a five pound note?

**Y5 optional test 2003 Mental test level 3**

I had one pound.  
I bought two cartons of drink and got thirty pence change.  
How much did each carton of drink cost?

**KS2 2006 Mental test level 3**

Boat Hire	
Motor boats £1.50 for 15 minutes	Rowing boats £2.50 for 1 hour

How much does it cost to hire a rowing boat for three hours?

Sasha pays £3.00 to hire a motor boat.  
She goes out at 3:20 pm.  
By what time must she return?

**KS2 2001 Paper B level 3**

One length of the swimming pool is 25 metres.  
Jane swims 5 lengths of the pool.  
How far does Jane swim altogether?

Kiz swims 225 metres in the pool.  
How many lengths does he swim?

**KS1 2005 level 3**

A shop sells greetings cards. Each card has a price code on it. These are the codes.

code	price
AA	75p
BB	£1.15
CC	£1.55
DD	£1.70
EE	£1.99

Tina buys two cards. One card has code AA on it.  
The other card has code DD on it. How much does Tina pay?

Omar buys a card. He pays with a £2 coin. He gets 45p change. What is the code on his card?

**KS2 2002 Paper A level 3**

A fruit pie costs fifty-five pence.  
What is the cost of three fruit pies?

**KS2 2004 Mental test level 3**

These are the prices of coconuts and bananas.



coconuts  
78p each



bananas  
£1.20 for 1kg

Josh buys one coconut and half a kilogram of bananas. How much does he spend altogether?

Oranges cost 25p each. How many oranges can Josh buy for £1.50?

**KS2 2005 Paper B level 3**

A shop sells candles.



plain candles  
35p each



star candles  
60p each



stripe candles  
85p each

Sapna buys 4 star candles and 2 stripe candles.  
How much does she pay altogether?

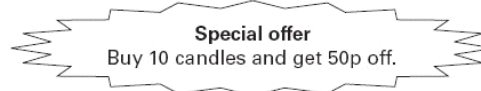

Josh buys 10 plain candles in the special offer.  
How much does he pay for the 10 candles?

**KS2 2005 Paper A level 3**

On a sheet of stickers there are 5 circles, 2 stars and one rectangle.

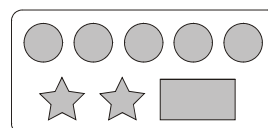

How many stickers are there altogether on 4 sheets?

Nisha needs 55 circles.

How many sheets of stickers does she need?

Ben has 10 sheets of stickers. How many more circles than rectangles does he have?

**KS2 2008 Paper A level 3**

- Represent a puzzle or problem using number sentences, statements or diagrams; use these to solve the problem; present and interpret the solution in the context of the problem

Harry worked out the correct answer to  $70 \div 5$ .  
His answer was 14.  
Show how he could have worked out his answer

**KS1 2003 level 3**

A plank 200 cm long is cut into 5 equal pieces.  
Which of these gives the length of each piece in centimetres?

- A  $200 \div 5$
- B  $200 \times 5$
- C  $200 - 5$
- D  $200 + 5$

Lin needs to solve this problem.  
'How many children are in the class?'

Tick (✓) all the information that Lin needs to solve her problem.

- There are 9 girls in the class.
- 5 girls in the class wear glasses.
- There are twice as many boys as girls in the class.

David needs to solve this problem.  
'How much do two oranges and one apple cost?'

Tick (✓) all the information that David needs to solve his problem.

- An orange costs 5p more than an apple.
- An apple costs 20p
- David has £1.70

**KS2 2006 Paper A level 3**

Here are some number cards.

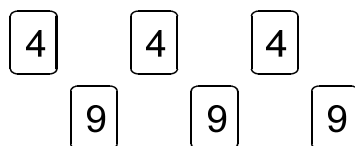

Use five of the number cards to make this correct.

$$\begin{array}{r} \square \quad \square \quad \square \\ + \quad \square \quad \square \\ \hline 5 \quad 4 \quad 8 \end{array}$$

**KS2 2001 Paper B level 3**



One battery weighs the same as **60** paperclips.

One pencil sharpener weighs the same as **20** paperclips.

How many pencil sharpeners weigh the same as one battery?

How many paperclips weigh the same as **2** batteries and **4** pencil sharpeners together?

**KS2 2009 Paper A level 3**

Here are four shapes.



They can be fitted together in a straight line so that there are no gaps between them.

Write the order of the letters of the shapes when they all fit together.

**KS2 2009 Paper B level**

Here are some amounts of money. Circle all the amounts that can be made with three coins.

71p   72p   73p   74p   75p

**KS2 2007 Paper B level 3**

The sum of two numbers is 100.  
Write in the missing digits.

$$\begin{array}{|c|} \hline 3 \\ \hline \end{array} \begin{array}{|c|} \hline \square \\ \hline \end{array} + \begin{array}{|c|} \hline \square \\ \hline \end{array} \begin{array}{|c|} \hline 3 \\ \hline \end{array} = \begin{array}{|c|} \hline 1 \\ \hline \end{array} \begin{array}{|c|} \hline 0 \\ \hline \end{array} \begin{array}{|c|} \hline 0 \\ \hline \end{array}$$

**KS2 2007 Paper B level 3**

Complete this diagram so that the three numbers in each line add up to 150

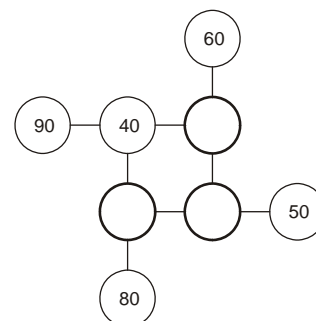

**KS2 2006 Paper A level 3**

- Suggest a line of enquiry and the strategy needed to follow it; collect, organise and interpret selected information to find answers

Class 6 did a survey of their favourite types of story book. Here are their results.

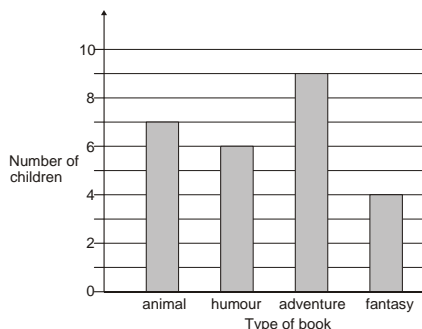

How many more children chose adventure books than fantasy books?

Five girls chose animal books.

How many boys chose animal books?

**KS2 2006 Paper B level 3**

Suggest two more questions you could ask about the information in the graph

Class 6 launched some balloons at a school fete. This diagram shows how far some of the balloons travelled.

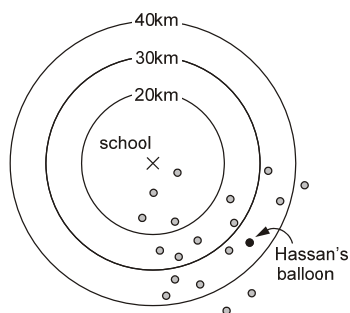

How many balloons on the diagram travelled between 20 km and 30 km?

Estimate how far Hassan's balloon travelled.

**KS2 2007 Paper A level 3**

Write two more questions you can ask about the information in the diagram.

This chart shows the musical instruments some children play.

	Lena	John	Rashid	Nicola	Yin
drums	✓	✓		✓	
keyboard			✓		
trumpet	✓				✓
recorder			✓	✓	✓
piano	✓	✓	✓		

Who plays both recorder and drums?

How many children play more than two musical instruments?

**KS2 2001 Paper B level 3**

Write another question you can ask about the information in the chart.

This chart shows the times when 5 children were at a swimming pool one afternoon.

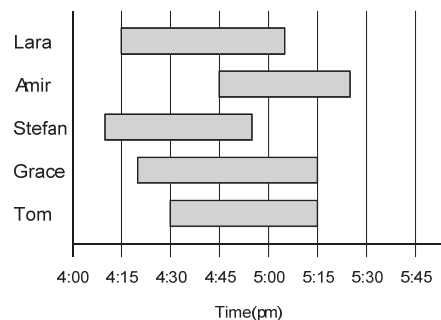

Who was the next person to arrive after Stefan?

Who spent the longest time at the swimming pool?

**KS2 2009 Paper B level 3**

Write two more questions you can ask about the information in the chart.

Park School collects money for three charities. This pictogram shows how much they have collected.

⊗ stands for £100

Save Dolphins	⊗	⊗	⊗	⊗	
Wildwatch	⊗	⊗	⊗		
Plant-a-Tree	⊗	⊗	⊗		

How much more have they collected for Save Dolphins than Plant-a-Tree?

The target for Wildwatch is £500. How much more money do they need to collect for Wildwatch?

How much money have they collected altogether, rounded to the nearest hundred pounds?

**KS2 2008 Paper A level 3**

Write two more questions you can ask about the information in the pictogram.

• Identify and use patterns, relationships and properties of numbers or shapes; investigate a statement involving numbers and test it with examples

Each missing digit in this sum is a 9 or a 1.  
Write in the missing digits.

$$\square\square + \square\square + \square\square = 201$$

KS2 2006 Paper B level 3

Here are four digit cards.



Use each of the digits once to make a total that is a multiple of 5.

$$\square\square + \square\square$$

Y5 optional test 2003 Paper A level 3

Here are five digit cards.



Use all five digit cards to make this correct.

$$\square\square \times 2 = \square\square\square$$

KS2 2004 Paper B level 3

Here are four shapes on a square grid.

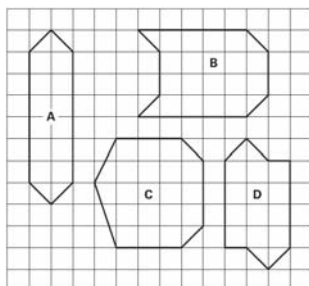

Complete the table.

	property of shape	
	is an octagon	has at least 1 right angle
shape A	✗	✓
shape B	✓	✗
shape C		
shape D		✓

Y4 optional test 2003 Paper A level 3

A square always has four sides.

Is it true that a four-sided shape is always a square?  
Circle Yes or No.

Explain how you know.

KS2 2008 Paper A level 3

Nisha says: 'When you halve any even number, the answer is always an odd number.'

Is she correct?

Circle Yes or No.

Explain how you know.

KS2 2008 Paper B level 3

The time is 10:35 am.

Kate says, 'The time is closer to 11:00 am than to 10:00 am.'

Explain why Kate is correct.

KS2 2007 Paper B level 3

John says, 'Every multiple of 5 ends in 5.'

Is he correct? Circle Yes or No.

Explain how you know.

KS2 2004 Paper B level 3

60 children visit the zoo.

They each vote for their favourite big cat.

Complete the table.

favourite big cat	number of children
cheetah	7
lion	22
tiger	13
panther	
leopard	10
<b>total</b>	<b>60</b>

Now look at each sentence below.

Put a tick (✓) if it is true.

Put a cross (✗) if it is not true.

- Nine more children voted for the lion than for the leopard.
- The lion was more popular than the tiger.
- $\frac{1}{4}$  of the children voted for the tiger.

Y3 Optional test 2003 paper A level 3

- Report solutions to puzzles and problems, giving explanations and reasoning orally and in writing, using diagrams and symbols

Here are five coins.



Stefan takes two coins and Lara takes the other three coins.  
Stefan takes 15p more than Lara.  
Tick (✓) the two coins Stefan takes.

**KS2 2009 Paper B level 3**

Peter and Stella compare colours they like and do not like. Here is a sorting diagram that shows their results.

	Peter likes	Peter does <b>not</b> like
Stella likes	red black	orange white
Stella does <b>not</b> like	purple green	yellow

Write the colours that Stella likes but Peter does **not** like.

Peter likes the colour blue but Stella does not. Write **blue** in the correct place on the sorting diagram above.

**Y4 optional test 2003 Paper A level 3**

Here is part of a number square.

The shaded numbers are part of a sequence.

113	114	115	116
123	124	125	126
133	134	135	136
143	144	145	146

Explain the rule for the sequence.

**Y5 Optional test 2003 Paper B level 3**

A shop has these special offers.

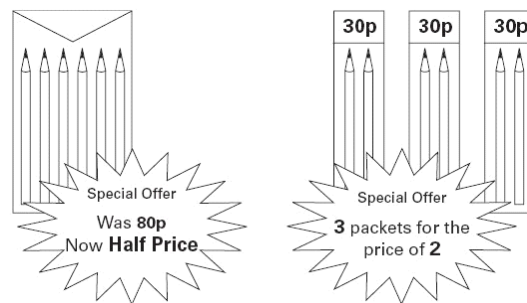

Joe wants to buy 6 pencils.  
Which is the cheaper offer?  
Tick (✓) one box.

Half price     3 for 2

Explain how you know.

**Y4 optional test 2003 Paper A level 3**

Here are some signs.



Write a sign in each box to make this correct.

$$20 \square 4 \square 5$$

**KS1 2003 level 3**

## Counting and understanding number

- Recognise and continue number sequences formed by counting on or back in steps of constant size

The numbers in this sequence increase by 75 each time. Write in the two missing numbers.

725 800 875 950

KS2 2008 Paper A level 3

Write in the missing number.

731 → 831 → 931 →

Y5 optional test 2003 level 3

Here is part of a number sequence. The numbers increase by the same amount each time.

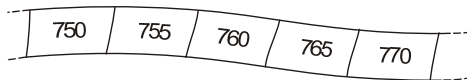

The sequence continues.

Circle all of the numbers below that would appear in the sequence.

840 905 989 1000 2051

KS2 2007 Paper A level 3

Here is part of a number square. The shaded numbers are part of a sequence.

113	114	115	116
123	124	125	126
133	134	135	136
143	144	145	146

Explain the rule for the sequence.

Y5 Optional test 2003 Paper B level 3

What is the next odd number after nine hundred and ninety-nine?

KS2 2007 Mental test level 3

Write the two missing numbers in this sequence.

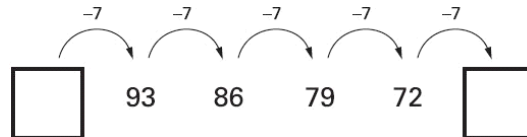

Y3 optional test 2003 level 3

Write in the missing number.

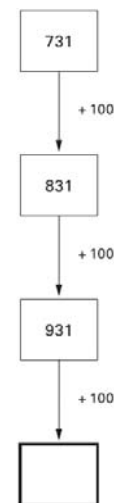

Y5 Optional test 2003 Paper A level 3

Here is part of a number line. Write the missing numbers in the boxes.

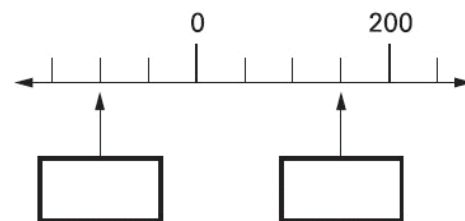

Y5 optional test 2003 level 4

- Partition, round and order four-digit whole numbers; use positive and negative numbers in context and position them on a number line; state inequalities using the symbols  $<$  and  $>$ , e.g.  $-3 > -5$ ,  $-1 < +1$

Write in figures the number one thousand and twenty.

**KS2 2003 Mental test level 3**

Write in figures the number six thousand and fifty-eight.

**KS2 2002 Mental test level 3**

Write these numbers in order of size, starting with the smallest.

901    1091    910    109    190

smallest

**KS2 2006 Paper A level 3**

Kiz has these numbers.

1330    1303    1033    1003    1030

He writes them in order from smallest to largest. What is the fourth number he writes?

**KS1 2005 level 3**

Circle the number nearest to 1000.

1060    1049    1100    960    899

**KS2 2001 Paper A level 3**

Draw an arrow ( $\uparrow$ ) to show the position for 7 500.

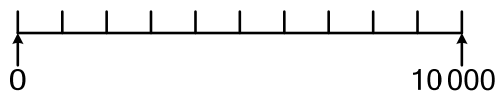

**Y4 Optional test 2003 level 3**

Write these temperatures in order from hottest to coldest.

92°C    37°C    -12°C    73°C    12°C    -2°C

The temperature in York is 4°C. Rome is 7 degrees colder than York. What is the temperature in Rome?

**KS2 2000 Paper A level 3**

Here is a number sentence.

$$3000 + \square + 40 + 7 = 3847$$

What number goes where the  $\square$  is to make the sentence true?

Draw two more lines to match 3500 to numbers with the same value.

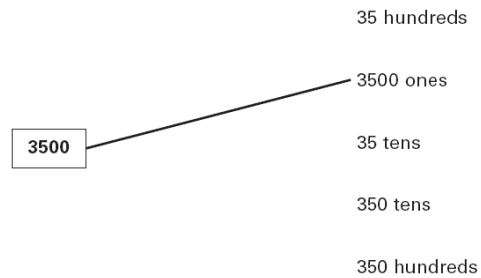

**Y4 optional test 2003 Paper B level 4**

Here is a number sentence.

$$5 \times \square < 18$$

Which number could go in the box to make the sentence true?

A 2    B 3    C 12    D 13

Use these signs.

= < >

Write the correct signs in the boxes.

$$4 \times 4 \quad \square \quad 2 \times 8$$

$$8 \times 7 \quad \square \quad 9 \times 6$$

$$5 \times 7 \quad \square \quad 5 \times 5$$

$$10 \times 6 \quad \square \quad 6 \times 10$$

**Y4 Optional test 1999 Paper B level 3**

Here are two signs.

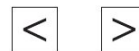

Use the signs to make these correct.

$$52 \square 17$$

$$18 \square 91$$

$$50 \square 34$$

**Y4 optional test 2003 Paper A level 3**

- Use decimal notation for tenths and hundredths and partition decimals; relate the notation to money and measurement; position one- and two-place decimals on a number line

Write these prices in order from smallest to largest.

KS2 2005 Paper B level 3

Here is part of a number line.  
 Write the missing number in the box.

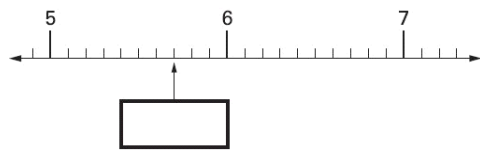

Y5 optional test 2003 Paper B level 3

Here is part of a number line. Write in the numbers missing from the two empty boxes.

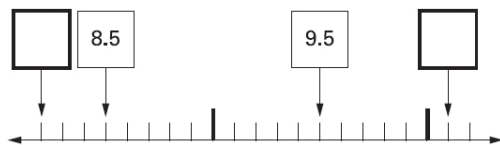

Y3 optional test 2003 Paper B level 3

Look at these amounts.

£70.07   £70.70   £7.70   £7.07

Write the amounts in order in the boxes.

£    £    £    £  
 least most

KS1 2003 level 3

Write in the missing numbers.  
 One has been done for you.

rounded to the nearest whole number is

6.01 →   
 9.51 →   
 7.75 →

Y5 Optional test 2003 Paper B level 3

- Recognise the equivalence between decimal and fraction forms of one half, quarters, tenths and hundredths

Which of these means  $\frac{7}{10}$ ?

- A 70   B 7   C 0.7   D 0.07?

0.4 is the same as

- A four  
 B four tenths  
 C four hundredths  
 D one-quarter

Circle the fraction that is the same as nought point five.

$\frac{1}{2}$     $\frac{1}{3}$     $\frac{1}{4}$     $\frac{3}{4}$

Put a ring around the fraction which is equal to nought point four.

$\frac{1}{4}$     $\frac{1}{40}$     $\frac{1}{400}$     $\frac{4}{10}$     $\frac{4}{100}$

KS2 2002 Mental test level 4



- Use diagrams to identify equivalent fractions, e.g.  $\frac{6}{8}$  and  $\frac{3}{4}$ , or  $\frac{70}{100}$  and  $\frac{7}{10}$ ; interpret mixed numbers and position them on a number line, e.g.  $3\frac{1}{2}$

What fraction of these rabbits is grey?

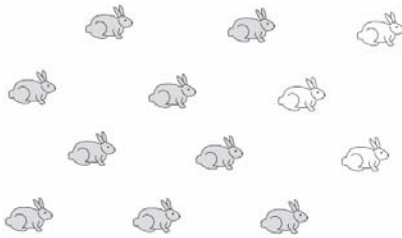

Write the fraction.

KS1 2005 level 3

Here is a square.

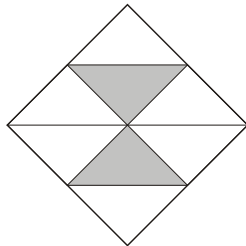

What fraction of the square is shaded?

KS2 2004 Paper A level 3

Here are five diagrams. Look at each one.  
Put a tick (✓) on the diagram if exactly  $\frac{1}{2}$  of it is shaded. Put a cross (✗) if it is not.

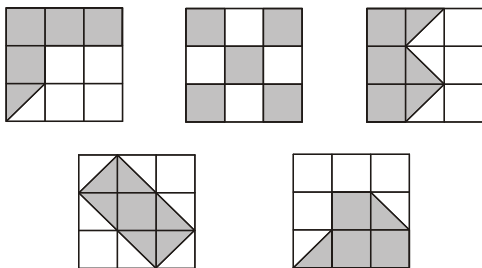

KS2 2007 Paper B level 3

A fraction of each shape is shaded. Match each fraction to the correct place on the number line.

One has been done for you.

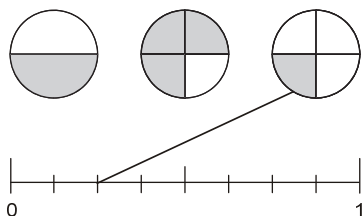

KS2 2009 Paper A level 3

Circle the two fractions that have the same value.

$$\frac{2}{10} \quad \frac{5}{10} \quad \frac{1}{3} \quad \frac{1}{2} \quad \frac{1}{4}$$

Y3 optional test 2003 Paper A level 3

Circle the two fractions that are greater than  $\frac{1}{2}$ .

$$\frac{1}{8} \quad \frac{6}{10} \quad \frac{5}{8} \quad \frac{3}{10}$$

Y4 optional test 2003 Paper A level 3

Draw an arrow on the number line to show  $1\frac{3}{4}$ .



Y4 optional test 2003 Paper A level 3

Write the two missing numbers in this sequence.

$$\frac{1}{4} \quad \frac{1}{2} \quad \frac{3}{4} \quad 1 \quad \square \quad 1\frac{1}{2} \quad 1\frac{3}{4} \quad \square$$

Y5 optional test 2003 Paper A level 3

Here is part of a number line.

Write in the two missing numbers.

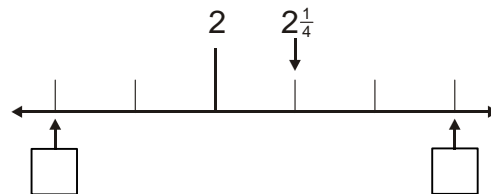

KS2 2004 Paper B level 4

- Use the vocabulary of ratio and proportion to describe the relationship between two quantities, e.g. 'there are 2 red beads to every 3 blue beads, or 2 beads in every 5 beads are red'; estimate a proportion, e.g. 'about one quarter of the apples in the box are green'

Mina has 76 marbles in a jar. The jar is about half full.

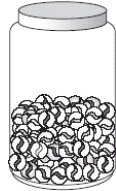

Estimate how many marbles Mina will have when the jar is full. Circle the best estimate.

75    100    125    150    175

**Y3 optional test 2003 Paper A level 3**

In this diagram, 2 out of every 3 squares are shaded.



Which diagram has 3 out of every 4 squares shaded?

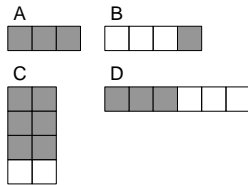

Tara has 4 books.  
 Ravi has 3 times as many books as Tara.



How many books do Tara and Ravi have altogether?

**KS1 2009 level 3**

In Li's class there are twice as many boys as girls. There are 8 boys in the class. What is the total number of boys and girls in the class?

A 12    B 16    C 20    D 24

For every stamp that Mark collected, Ali collected 3. Mark collected a total of 9 stamps. How many did Ali collect?

A 3    B 12    C 13    D 27

### Knowing and using number facts

- Use knowledge of addition and subtraction facts and place value to derive sums and differences of pairs of multiples of 10, 100 or 1000

What is one hundred and twenty add eighty?

**KS2 2006 Mental test level 3**

What is the total of one hundred and twenty and seventy?

**Y4 optional test 2003 Mental test level 3**

What is one thousand minus one hundred and ten?

**KS2 2004 Mental test level 3**

Add together ninety, one hundred and ten and one hundred and twenty.

**KS2 2008 Mental test level 3**

How much must I add to four pounds ninety to make six pounds?

**KS2 2003 Mental test level 3**

How many hundreds are there in one thousand?

**KS2 2008 Mental test level 3**

Calculate the difference between five hundred and two hundred and thirty.

**KS2 2000 level 4**

Write the answer.

$$200 - 90 - 80 = \square$$

**KS1 2000 level 3**

Circle three numbers which add to make 190.

10    30    50    70    90

**KS2 2001 Paper B level 3**

• Identify the doubles of two-digit numbers; use to calculate doubles of multiples of 10 and 100 and derive the corresponding halves

What is double ninety?

**KS2 2009 Mental test level 3**

What is double thirty-four?

**KS2 2005 Mental test level 3**

What is double forty-five?

**KS2 2000 Mental test level 3**

What is double sixty-seven?

**Y5 optional test 2003 Mental test level 3**

Double one hundred and fifty and then double the answer.

**KS2 2008 Mental test level 3**

Write the missing numbers in this sequence.

64 32 16  4

**Y5 Optional test 2003 Paper B level 3**

Join each box to the correct number.  
One has been done for you.

<input type="checkbox"/> $6 \times 5$	30
<input type="checkbox"/> half of 98	32
<input type="checkbox"/> double $4 \times 4$	44
	49

**KS2 2008 Paper A level 3**

Halve twenty-seven.

**KS2 2009 Mental test level 3**

What is half of eight hundred and sixty?

**KS2 2001 Mental test level 3**

What number is exactly half way between fifty and eighty?

**KS2 2008 Mental test level 3**

What is half of ninety pence?

**KS2 2006 Mental test level 3**

What is half of seven pounds?

**KS2 2007 Mental test level 3**

Hayley makes a sequence of numbers.

Her rule is 'find half the last number then add 10'.

Write in the next two numbers in her sequence.

36 28 24

**KS2 2003 Paper B level 3**

• Derive and recall multiplication facts up to  $10 \times 10$ , the corresponding division facts and multiples of numbers to 10 up to the tenth multiple

What is four multiplied by nine?

KS2 2005 Mental test level 4

Multiply seven by six.

KS2 2003 Mental test level 4

Multiply eight by seven.

KS2 2002 Mental test level 4

What is eight multiplied by six?

Y3 optional test 2003 Mental test level 3

Multiply eight by four, then add fifty.

KS2 2007 Mental test level 3

Add together eight and seven, then multiply the result by four.

KS2 2006 Mental test level 3

Leila puts 4 seeds in each of her pots. She uses 6 pots and has 1 seed left over. How many seeds did she start with?

KS2 2004 Paper A level 3

Each card on the left matches one on the right. Draw lines to match the cards which are equal in value. One has been done for you.

$3 \times 6$	$2 \times 25$
$10 \times 5$	$9 \times 2$
$5 \times 8$	$50 \times 2$
$9 \times 10$	$3 \times 30$
$5 \times 20$	$10 \times 4$

KS2 2000 Paper A level 3

Nineteen marbles are shared between some children. Each child receives six marbles and there is one marble left over. How many children share the marbles?

Y5 optional test 2003 Mental test level 3

Circle three numbers that add to make a multiple of 10.

11 12 13 14 15 16 17 18 19

KS2 2005 Paper A level 3

Write each of these numbers in its correct place on the sorting diagram.

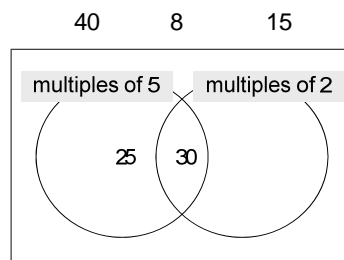

KS2 2000 Paper A level 3

A shop sells postcards in packs of 6 and packs of 8. Alan bought 4 packs of 8 cards. How many cards did he get?

Shereen bought some packs of 6 cards. Altogether she has 30 cards. How many packs of 6 did she buy?

KS2 2000 Paper B level 3

Divide forty-eight by eight.

KS2 2004 Mental test level 4

Circle all the multiples of 8 in this list of numbers.

18 32 56 68 72

KS2 2002 Paper A level 4

• Use knowledge of rounding, number operations and inverses to estimate and check calculations

Here is a multiplication.

$$6 \times 10 = 60$$

Write a division which uses these same 3 numbers.

**Y4 optional test 2003 Paper A level 3**

Circle the number that is about the same as the correct answer to  $49 + 48$ .

10   50   40   100   70   200

**Y4 Optional test 2003 level 3**

Write a calculation that you could do to check that the answer to  $53 \times 4$  is 212.

Draw a line from each card to the correct part of the number line. One has been done for you. You may use a calculator.

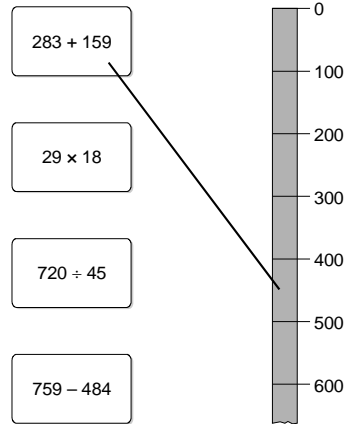

**KS2 2002 Paper B level 3**

• Identify pairs of fractions that total 1

Tick (✓) two cards that give a total of 5.

$1\frac{1}{4}$	$1\frac{1}{2}$	$1\frac{3}{4}$
$3\frac{1}{2}$	$3\frac{3}{4}$	$4\frac{1}{4}$

**KS2 2002 Paper A level 3**

$\frac{3}{8}$  of a class are boys.

What fraction are girls?

**Y5 Optional test 1998 Paper B level 3**

What is one and a half added to four and a half?

**KS2 2000 Mental test level 3**

## Calculating

• Add or subtract mentally pairs of two-digit whole numbers, e.g.  $47 + 58$ ,  $91 - 35$

Add together six and sixty-six.

**KS2 2007 Mental test level 3**

Add together twenty-three and forty-eight.

**KS2 2005 Mental test level 3**

What number is thirty-four more than fifty-eight?

**KS2 2003 Mental test level 3**

Add three hundred and eight to four hundred and two.

**KS2 2006 Mental test level 3**

Subtract twenty-one from forty.

**KS2 2008 Mental test level 3**

How many less than forty-one is seventeen?

**Y4 optional test 2003 Mental test level 3**

Take away ninety-five from one hundred and ten.

**KS2 2007 Mental test level 3**

Subtract one hundred and five from two hundred.

**KS2 2004 Mental test level 3**

Subtract three hundred and ninety-nine from eight hundred.

**KS2 2009 Mental test level 3**

What is one thousand minus one hundred and ten?

**KS2 2004 Mental test level 3**

Add one pound twenty to two pounds seventy-eight.

**KS2 2008 Mental test level 3**

I had one pound.

I bought two cartons of drink and got thirty pence change.

How much did each carton of drink cost?

**KS2 2006 Mental test level 3**

Add together nine, nineteen and twenty-nine.

**KS2 2007 Mental test level 3**

Add together thirteen, forty-seven and twenty-one.

**Y5 optional test 2003 Mental test level 3**

Add together twenty-three, thirty-three and forty-three.

**KS2 2004 Mental test level 3**

Add together fifty-three, fifty-five and fifty-seven.

**KS2 2002 Mental test level 3**

Add together fourteen, twenty-three and forty-one.

**KS2 2001 Mental test level 3**

Add together twenty, twenty-three and twenty-six.

**KS2 2009 Mental test level 3**

Add together ninety, one hundred and ten and one hundred and twenty.

**KS2 2008 Mental test level 3**

Write in the missing numbers.

$$\square + 75 = 90$$

**KS2 2007 Paper A level 3**

This table shows where 100 people went on holiday in 2007 and 2008.

	2007	2008
Spain	18	26
England	38	17
Scotland	21	13
Wales	19	28
USA	4	16

Look at the table. How many more people went to Wales than to Scotland in 2008?

Which country had the greatest increase in visitors from 2007 to 2008?

**KS2 2009 Paper A level 3**

• Refine and use efficient written methods to add and subtract two- and three-digit whole numbers and £.p

Calculate  $584 + 79$ .

Y5 optional test 2003 Paper A level 3

Calculate  $369 + 251$ .

KS2 2000 Paper A level 3

Calculate  $239 + 182$ .

KS2 2008 Paper A level 3

Calculate  $137 - 65$ .

Y5 optional test 2003 Paper A level 3

Calculate  $309 - 198$ .

KS2 2003 Paper A level 3

Here are four digit cards.

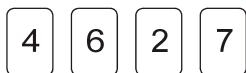

Use all four digit cards to make this sum correct.

$$\square\square + \square\square = 100$$

KS2 2009 Paper A level 3

Here are four digit cards.



Use each of the digits once to make a total that is a multiple of 5,

$$\square\square + \square\square$$

Y5 Optional test Paper A level 3

Circle one number in each box to make a total of 1000.

150		150
250	200	250
350	400	350
450		450

KS2 2007 Paper A level 3

The diagram shows distances on a train journey from Exeter to York.

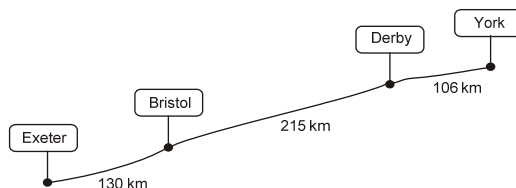

How many kilometres is it altogether from Exeter to York?

What is the distance from Derby to York rounded to the nearest 10 km?

KS2 2006 Paper A level 3

These are the prices of sandwiches, drinks and fruit.

Sandwiches		Drinks		Fruit	
ham	£1.45	milk	55p	apple	15p
tuna	£1.70	cola	45p	pear	20p
salad	£1.20	juice	65p	melon	25p

Shereen buys a tuna sandwich, milk and a pear. How much does she pay?

Mike has 80p to spend on a fruit and a drink. What two things can he buy for exactly 80p?

KS2 2004 Paper A level 3

Chen has £9.10.

He wants to buy a game which costs £11.50. How much more does he need to save?

Y4 Optional test 2003 Paper A level 3

Here are three bags in a shop

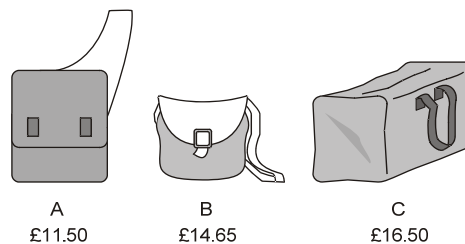

How much does bag B cost to the nearest pound?

Jamie buys bag A and bag C.

How much change does he get from £40?

KS2 2007 Paper A level 3

- Multiply and divide numbers to 1000 by 10 and then 100 (whole number answers), understanding the effect; relate to scaling up or down

Write in the missing number.

$$\square \div 10 = 20$$

Write in the missing numbers.

$$5 \times 70 = \square$$

$$4 \times \square = 200$$

**KS2 2002 Paper A level 3**

Write in the missing number.

$$600 \times 4 = \square$$

**Y3 Optional test 2003 Paper A level 3**

Write in the missing numbers.

$$4 \times \square = 200$$

**KS2 2007 Paper A level 3**

Circle all the multiples of 10.

640      500      404  
170      26      195  
30      531

**Y3 optional test 2003 Paper B level 3**

What is fifty-six multiplied by ten?

**[mental question]**

If one hundred and sixty children are put into groups of ten children, how many groups will there be?

**[mental question]**

How many hundreds are there in one thousand?

**KS2 2008 Mental test level 3**

Divide three hundred and ninety by ten.

**KS2 2001 Mental test level 4**

What is sixty-five multiplied by one hundred?

**Y4 optional test 2003 Mental test level 4**



- Develop and use written methods to record, support and explain multiplication and division of two-digit numbers by a one-digit number, including division with remainders, e.g.  $15 \times 9$ ,  $98 \div 6$

What is thirty multiplied by seven?

**KS2 2004 Mental test level 3**

One orange costs nineteen pence.  
 How much will three oranges cost?

**Y4 Optional test 2003 Mental test level 3**

Write in the missing number.

$$5 \times 70 = \square$$

**KS2 2002 Paper A level 3**

Sarah's cat eats one tin of this cat food each day.

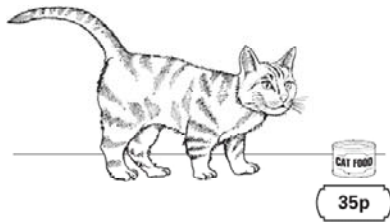

How much does it cost to feed Sarah's cat for 7 days?

**Y4 optional test 2003 Paper A level 3**

50 children need two pencils each.

There are 20 pencils in a box.

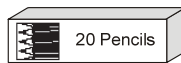

How many boxes of pencils are needed?

50 children need one pen each.

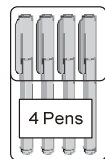

Pens are sold in packs of 4  
 How many packs of pens need to be bought?

**KS2 2007 Paper B level 3**

Here is a CD rack.

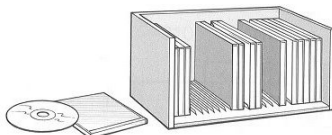

One rack holds 25 CDs.  
 David has 83 CDs.  
 How many racks does he need to hold all his CDs?

Lin has 6 racks full of CDs.  
 How many CDs does Lin have altogether?

**KS2 2006 Paper A level 3**

Divide ninety by three.

**KS2 2003 Mental test level 3**

What is the remainder when you divide 53 by 8?

**Y4 optional test 2003 Paper A level 3**

Circle each number which has a remainder of 2 when divided by 5.

27 15 26 45 32 24

**Y5 Optional test 1998 Paper A level 3**

Write in the missing numbers.

$$4 \times \square = 200$$

**KS2 2002 Paper A level 3**

Write the answer.

$$84 \div 7 =$$

**Y4 optional test 2003 Paper A level 4**

Calculate  $48 \div 3$ .

**KS2 2009 Paper A level 3**

Calculate  $56 \div 4$ .

**KS2 2005 Paper A level 3**

A shop sells batteries in packs of 4 and packs of 2.

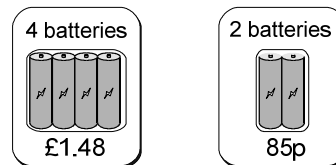

Simon and Nick want two batteries each.  
 They buy a pack of four and share the cost equally.  
 How much does each pay?

Mary buys 2 packs of two batteries.  
 Hamid buys 1 pack of four.  
 How much more does Mary pay than Hamid?

**KS2 2000 Paper A level 3**

- Find fractions of numbers, quantities or shapes, e.g.  $\frac{1}{5}$  of 30 plums,  $\frac{3}{8}$  of a 6 by 4 rectangle

What is one-fifth of twenty-five?

**Y4 Optional test 2003 Mental test level 3**

Write the missing number to make this correct.

$$\frac{1}{4} \text{ of } 24 = \frac{1}{2} \text{ of } \square$$

**KS1 2004 level 3**

Which number comes halfway between 330 and 410? Write it in the box.

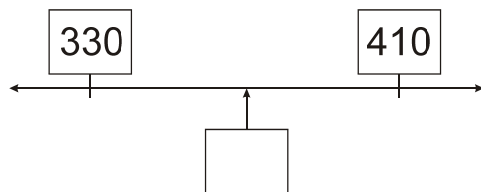

**KS1 2004 level 3**

Meg has 20 pet stickers to go on this page.

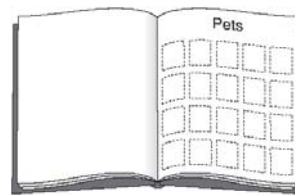

$\frac{1}{4}$  of them are dog stickers.

$\frac{1}{2}$  of them are cat stickers.

The rest are rabbit stickers.

How many rabbit stickers does she have?

**Y4 optional test 2003 Paper A level 3**

Match each box to the correct number. One has been done for you.

$\frac{1}{2}$  of 30

$\frac{1}{3}$  of 75

$\frac{1}{5}$  of 150

45

40

35

30

25

20

15

**KS2 2001 level 4**

What is three-quarters of two hundred?

**KS2 2000 Mental test level 4**

- Use a calculator to carry out one- and two-step calculations involving all four operations; recognise negative numbers in the display, correct mistaken entries and interpret the display correctly in the context of money

Write in the missing number.

$$225 - \square = 150$$

**KS2 2003 Paper B level 3**

Write in the missing number.

$$60 + 99 + \square = 340$$

**KS2 2000 Paper B level 3**

Write in the missing number.

$$22 \times \square = 660$$

**KS2 2002 Paper B level 3**

Write in the missing number.

$$8 \times \square = 400$$

**KS2 2001 Paper B level 3**

Write in the missing numbers.

$$35 \times \square = 140$$

$$633 - \square = 34$$

**KS2 2006 Paper B level 3**

Write in the missing numbers.

$$37 \times \square = 111$$

$$\square \div 4 = 21$$

**KS2 2003 Paper B level 3**

Tick (✓) each multiplication that has an answer greater than 1000

- |             |                          |
|-------------|--------------------------|
| 12 × 11 × 8 | <input type="checkbox"/> |
| 13 × 9 × 8  | <input type="checkbox"/> |
| 14 × 11 × 6 | <input type="checkbox"/> |
| 15 × 12 × 6 | <input type="checkbox"/> |

**KS2 2009 Paper B level 3**



Bottle of milk  
39p



cake  
29p

Ben buys three bottles of milk and six cakes.  
 How much does he spend altogether?

**KS2 2008 Paper B level 3**

Plants are sold in trays of 20. Ivana buys 7 trays of plants. How many plants is this?

David wants 240 plants.  
 How many trays does he need to buy?

**KS2 2001 Paper B level 3**

These are the prices in a shoe shop.



boots  
£45.50



sandals  
£12.75



trainers  
£34.99

How much more do the boots cost than the trainers?

Rosie buys a pair of trainers and a pair of sandals.  
 How much change she gets from £50?

**KS2 2006 Paper B level 3**

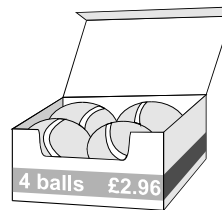

A box of four balls costs £2.96.  
 How much does each ball cost?

Dean and Alex buy 3 boxes of balls between them.  
 Dean pays £4.50.  
 How much must Alex pay?

**KS2 2002 Paper B level 3**

Plastic cups are sold in packs of 8.  
 Amir needs 27 cups.  
 How many packs must he buy?

There are 30 paper plates in a pack.  
 Amir buys 2 packs.  
 He uses 37 plates.  
 How many plates are left?

**KS2 2009 Paper B level 3**

Emily has these coins.



How much more money does Emily need to make exactly £5?

Nisha has thirty 5p coins and twenty 10p coins.  
 How much money does she have altogether?

**KS2 2008 Paper B level 3**

## Understanding shape

- Draw polygons and classify them by identifying their properties, including their line symmetry

The lines drawn on the grid are two sides of a pentagon. Complete the pentagon. Use a ruler.

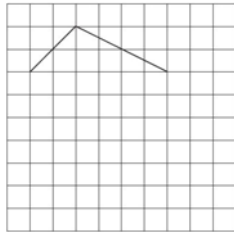

**Y5 Optional test 2003 Paper A level 3**

On the grid join dots to make a triangle which does not have a right angle. Use a ruler.

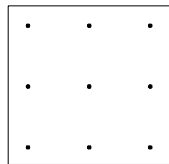

**KS2 2002 Paper B level 3**

Here are five quadrilaterals on a square grid. A dotted line has been drawn on each quadrilateral.

For each shape, put a tick (✓) if the dotted line is a line of symmetry. Put a cross (✗) if it is not.

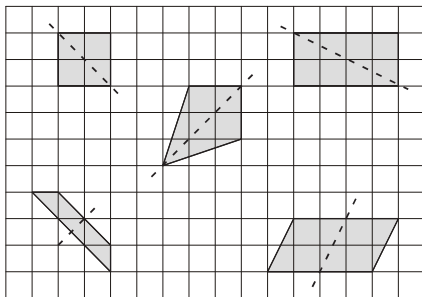

**KS2 2009 Paper B level 3**

Put ticks (✓) and crosses (✗) on the chart to complete it correctly. One has been done for you.

Shape	It is a quadrilateral	It has one or more right angles
	✗	✓

**KS2 2006 Paper B level 3**

Here are five shapes on a square grid.

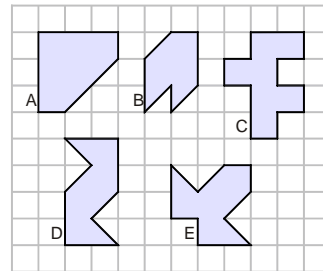

Write the letters of the two shapes which have a line of symmetry.

**KS2 2004 Paper A level 4**

Draw the reflection of the shaded shape in the mirror line. Use a ruler.

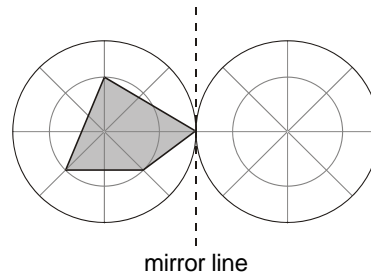

**KS2 2008 Paper A level 3**

Draw the reflection of the shaded shape in the mirror line. Use a ruler.

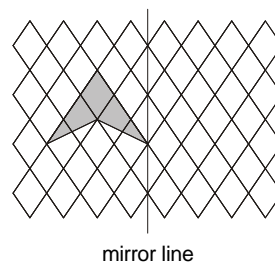

**KS2 2007 Paper B level 3**

Shade in two more squares to make this design symmetrical about the mirror line. You may use a mirror or tracing paper.

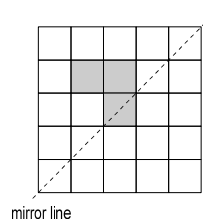

**KS2 2001 Paper B level 3**

• Visualise 3-D objects from 2-D drawings; make nets of common solids

This table shows information about four solid shapes. Complete the table. One has been done for you.

	number of flat surfaces	number of curved surfaces
sphere	0	1
cone		
cuboid		
cylinder		

KS2 2005 Paper B level 3

Tom makes this shape from four cubes stuck together. Two circles are drawn on the shape.

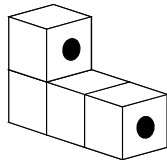

Tom moves the shape. Draw the circles on the shape in its new position.

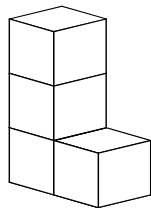

KS2 2001 Paper B level 3

Complete the table.

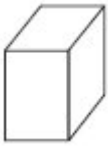
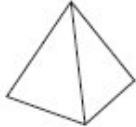
	number of faces	number of edges
 cuboid	6	12
 square-based pyramid	5	

Y3 Optional test 2003 Paper B level 3

Two of these diagrams are nets for a triangular prism. Put a tick (✓) in them.

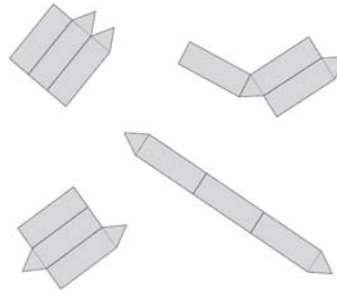

Y4 Optional test 2003 Paper A level 3

Here are some nets of shapes.

For each net, put a tick (✓) if it folds to make a pyramid. Put a cross (✗) if it does not.

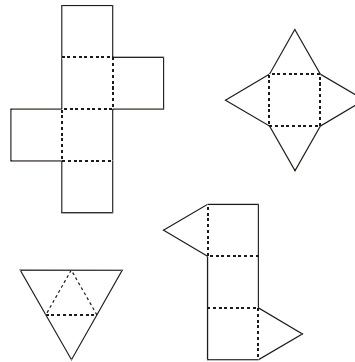

KS2 2008 Paper B level 3

This table shows information about four solid shapes. Complete the table.

One has been done for you.

	number of flat surfaces	number of curved surfaces
sphere	0	1
cone		
cuboid		
cylinder		

KS2 2007 Paper B level 3

How many vertices has a cuboid?

Y4 optional test 2003 Mental test level 3

- Recognise horizontal and vertical lines; use the eight compass points to describe direction; describe and identify the position of a square on a grid of squares

The shaded rectangle covers squares (D, 4) and (E, 4).

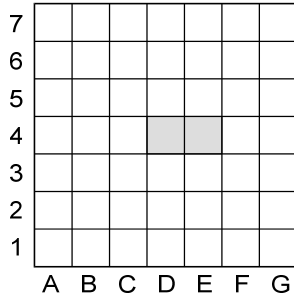

Draw and shade the rectangle that covers (B, 5) and (B, 6).

Y3 Optional test 2003 Paper B level 2

Lisa places a counter on square D4.

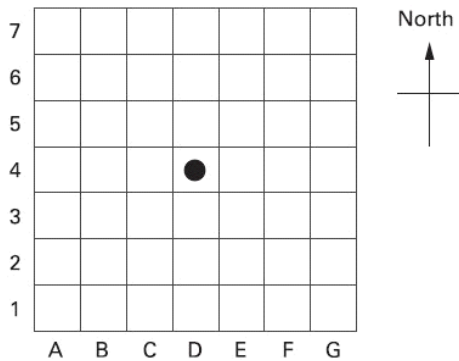

She moves it 2 squares east and 3 squares south. Write the position of the square she moves it to.

Y4 optional test 2003 Paper B level 3

The arrow is pointing north-east.

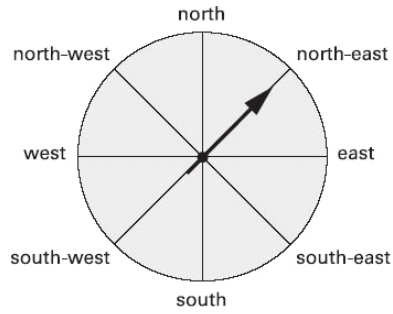

The arrow is moved a quarter turn clockwise. In which direction is the arrow pointing after it is moved?

Y4 optional test 2003 Paper A level 3

The arrow labelled N is pointing north. Which arrow is pointing south-west? Put a ring round the correct arrow.

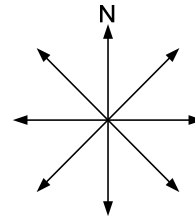

Amy is facing North. She turns clockwise through 2 right angles. Which direction is she facing now?

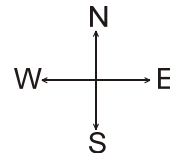

Rashid is facing West. He turns clockwise through 3 right angles. Which direction is he facing now?

- Know that angles are measured in degrees and that one whole turn is  $360^\circ$ ; compare and order angles less than  $180^\circ$

Two of these angles are the same size. Put rings around the two angles which are the same size.

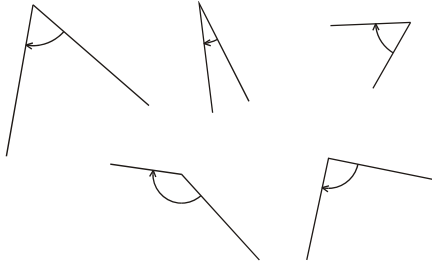

Look at these six angles.

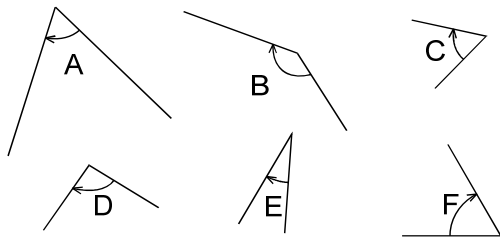

- Which is the smallest angle?
- One of the angles is a right angle. Which is a right angle?
- One of the angles is an obtuse angle. Which is an obtuse angle?

Look at this shape.

Tick (✓) each angle that is less than a right angle.

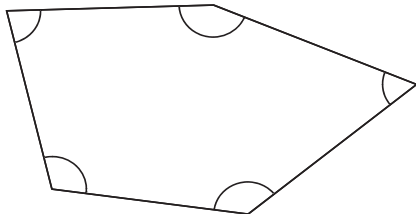

KS2 2009 Paper B level 3

A shape has 4 right angles.  
 It has 4 sides which are not all the same length.  
 Write the name of this shape.

Y4 Optional test 2003 Paper B level 3

Here is an arrow.



The arrow is rotated  $90^\circ$  clockwise.  
 In which direction does the arrow now point?  
 Put a tick (✓) by the correct answer.

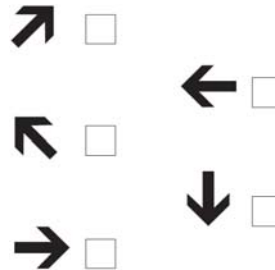

Y5 optional test 2003 Paper A level 3

Here is a tile.



The tile is turned.

One of the diagrams below shows the tile after it has been turned. Tick (✓) the correct diagram.

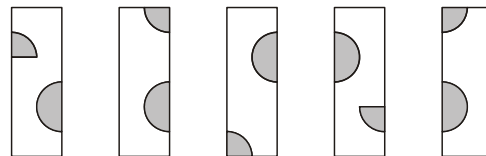

KS2 2007 Paper A level 3

Stefan makes this design on a square tile.

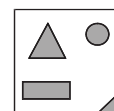

He turns the tile.

Put a tick (✓) on the tile below that has the same design as Stefan's tile.

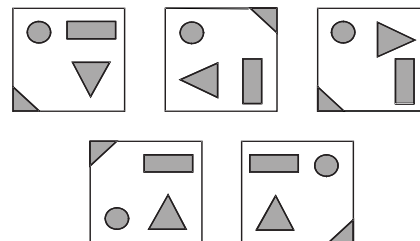

KS2 2009 Paper B level 4

## Measuring

- Choose and use standard metric units and their abbreviations when estimating, measuring and recording length, weight and capacity; know the meaning of kilo, centi and milli and, where appropriate, use decimal notation to record measurements, e.g. 1.3 m or 0.6 kg

How many millimetres are in three centimetres?

**KS2 2008 Mental test level 4**

How many centimetres are there in two and a half metres?

**Y5 Optional test 2003 Mental test level 3**

How many metres are there in four and a half kilometres?

**KS2 2004 Mental test level 4**

Put these times in order, starting with the shortest.

5 minutes	20 seconds	100 seconds
1 minute		

--	--	--	--

shortest

**KS2 2008 Paper A level 3**

Kate has a piece of ribbon one metre long. She cuts off 30 centimetres.



How many centimetres of ribbon are left?

**KS2 2007 Paper A level 3**

Two of these sentences could be true. Tick (✓) the two sentences that could be true.

- Adam's pencil is 12 centimetres long.
- Leah is 12 metres tall.
- Jake's glass holds 12 litres of milk.
- Kate's younger sister weighs 12 kilograms.

**Y4 optional test 2003 Paper A level 3**

Robin has bought a packet of biscuits.

Tick (✓) the amount the biscuits are most likely to weigh.

- 10 kg
- 250 kg
- 5 g
- 250 g
- 10 g
- 5 kg

**Y4 Optional test 1998 Paper B level 3**

Which value completes each sentence?

Tick (✓) the correct box.

The length of a banana is about ...

- 2 cm
- 20 cm
- 200 cm
- 2000 cm

Katie's glass holds a quarter of a litre when it is full. She nearly fills it to the top with juice.

Tick (✓) the approximate amount of juice she puts in the glass.

- |                 |                          |
|-----------------|--------------------------|
| 4 millilitres   | <input type="checkbox"/> |
| 20 millilitres  | <input type="checkbox"/> |
| 120 millilitres | <input type="checkbox"/> |
| 220 millilitres | <input type="checkbox"/> |
| 420 millilitres | <input type="checkbox"/> |

**Y3 Optional test 2003 Paper B level 4**



- Interpret intervals and divisions on partially numbered scales and record readings accurately, where appropriate to the nearest tenth of a unit

Measure accurately the length of the diagonal of this square.

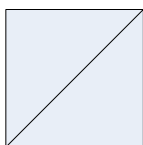

Give your answer in centimetres.

**KS2 2004 Paper A level 3**

Jamie is cooking pasta.  
 He weighs 350 grams of pasta.  
 Draw an arrow on the scale to show 350 grams.

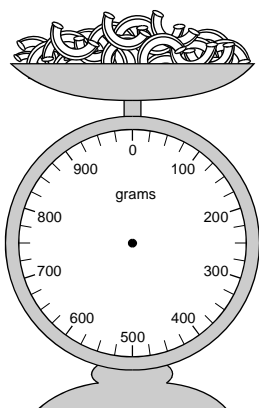

**KS2 2003 Paper A level 3**

Here is a baby's drinking cup.

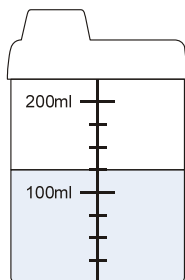

How many millilitres of water are in the cup?

**KS2 2006 Paper B level 3**

Here is a scale which shows the weight of a letter.

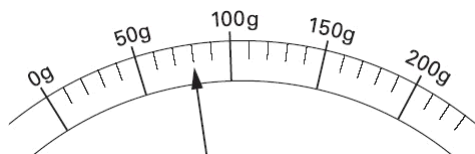

How much does the letter weigh?

**Y3 Optional test 2003 Paper A level 3**

Measure accurately the length of the shortest side of this triangle.

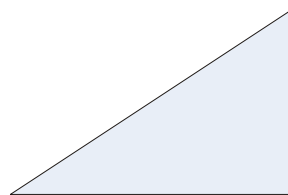

Write your answer in centimetres.

**KS2 2007 Paper B level 3**

Emily is making a cake. She puts flour on the scales. She then adds sugar to the flour.

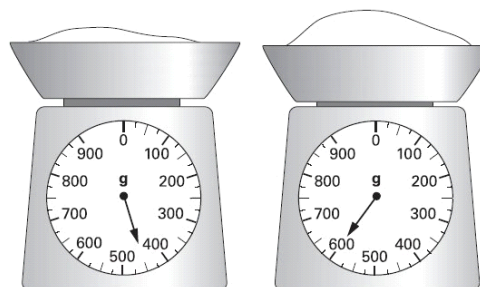

How much sugar does she add?

**Y5 optional test 2003 Paper B level 3**

Hassan has a jug with some water in it.  
 He adds another 140 millilitres of water.  
 Draw a line to show the new level of water.

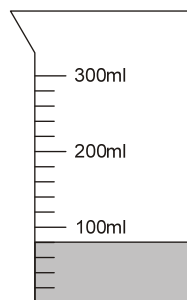

**KS2 2007 Paper B level 4**

Here are some apples.

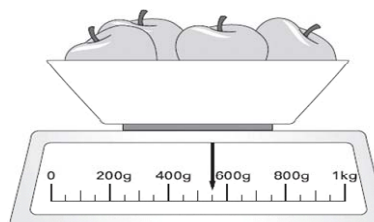

What is the total weight of these apples?

**Y5 optional test 2003 Paper A level 4**

- Draw rectangles and measure and calculate their perimeters; find the area of rectilinear shapes drawn on a square grid by counting squares

Draw two more straight lines to make a rectangle.  
 Use a ruler.

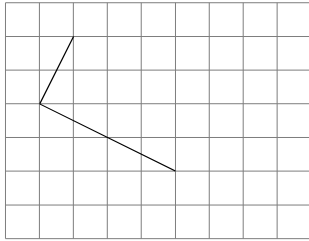

KS2 2001 Paper A level 3

Match each shape on the left to one with equal area on the right. One has been done for you.

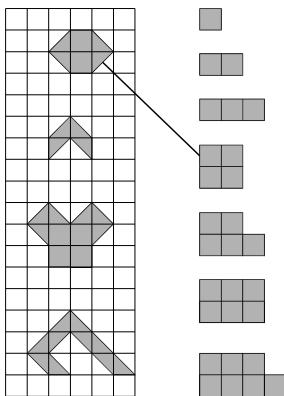

KS2 2002 Paper A level 3

Draw one line from each shape to the rectangle which has the same area.  
 One is done for you.

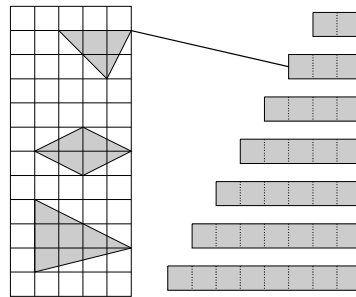

KS2 1999 Paper A level 3

Here is a 1cm square grid.  
 Some of the grid is shaded.

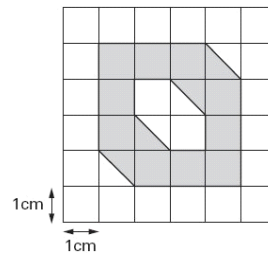

What is the area that is shaded?

KS2 2005 Paper B level 4

- Read time to the nearest minute; use am, pm and 12-hour clock notation; choose units of time to measure time intervals; calculate time intervals from clocks and timetables

Here are two clock faces.  
 Join each clock face to the correct digital time.

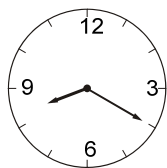

- 9:20
- 3:40
- 4:40
- 8:40
- 8:20
- 4:20

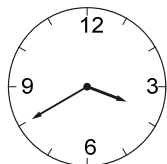

KS2 2008 Paper B level 3

A clock shows this time.

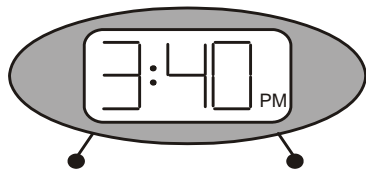

How long is it from this time until 5pm?  
 What time was it quarter of an hour before the time on the clock?

KS2 2006 Paper A level 3

How many hours are there in two days?

KS2 2004 Mental test level 3

What time is it half an hour after ten-fifteen?

KS2 2009 Mental test level 3

My watch shows two-fifty p.m.  
 What time will it show in thirty minutes?

KS2 2001 Mental test level 3

What is the time twenty minutes after nine fifty-five?

KS2 2002 Mental test level 3

Circle the time that is 30 minutes before midnight.

- 12:30 am      12:30 pm
- 11:30 am      11:30 pm      3 am

KS2 2009 Paper A level 3

Jamie makes a time line of part of his day.

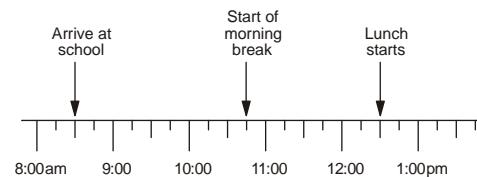

What time does Jamie's morning break start?

Lunch lasts for three-quarters of an hour.  
 What time does lunch finish?

KS2 2007 Paper A level 3

These are the radio programmes one morning.

7:00	Music show
7:55	Weather report
8:00	News
8:15	Travel news
8:25	Sport
8:45	Holiday programme

Josh turns the radio on at 7:25 am. How many minutes does he wait for the Weather report?

The Holiday programme lasts for 40 minutes. At what time does the Holiday programme finish?

KS2 2005 Paper A level 3

These are the opening times at a swimming pool.

	opening times	
	am	pm
Monday	Pool closed	
Tuesday	Pool closed	
Wednesday	10:30	to 5:30
Thursday	10:30	to 8:30
Friday	10:30	to 9:00
Saturday	8:00	to 6:00
Sunday	7:00	to 4:00

How many hours is the pool open on a Sunday?

Which day has the latest closing time?

Roy arrives at the pool at 5:20pm on Saturday. How many minutes is it before the pool closes?

KS2 2000 Paper B level 3

A film starts at 6:45 pm.  
 It lasts 2 hours and 35 minutes.  
 What time will the film finish?

KS2 2004 Paper A level 4

## Handling data

- Answer a question by identifying what data to collect; organise, present, analyse and interpret the data in tables, diagrams, tally charts, pictograms and bar charts, using ICT where appropriate

Robbie collected information about the colours of some bikes. Here are his results.

Colour	Number of bikes
green	4
red	7
blue	12
pink	3

This bar graph shows the information from the table. Fill in all the missing labels.

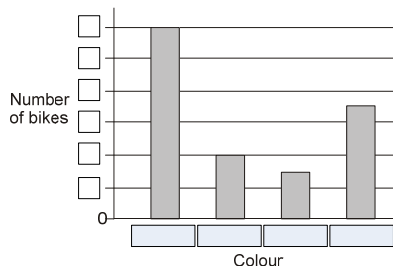

### KS2 2005 Paper A level 3

This table shows the numbers of children who went walking, sailing or climbing at an outdoor centre.

	May	June	July
walking	25	80	75
sailing	15	42	50
climbing	18	27	23

How many children went sailing in May, June and July altogether?

How many more children went walking in June than climbing in June?

### KS2 2000 Paper A level 3

Kiz asked each child in his class, 'What kind of television programme do you prefer to watch?' Here are his results.

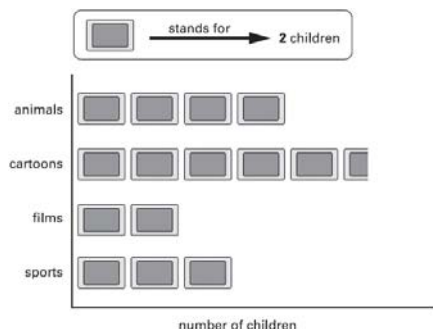

How many more children prefer to watch cartoons than films?

### Y5 optional test 2003 Paper B level 3

Rosie collects data about birds visiting a bird table. Here are her results.

Blackbird	
Sparrow	
Robin	
Blue tit	
Other	



Draw two more lines to complete the graph.



Rosie saw 20 birds altogether. What fraction of the birds were blackbirds?

### KS2 2006 Paper A level 3

This chart shows the number of cars in a car park at different times on one day.

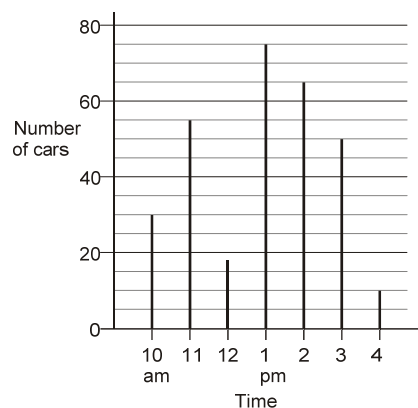

There are 80 cars in the car park when it is full. How many empty spaces were there in the car park at 3pm?

Circle all the times when the car park was less than half full.

10 am 11 am 12 noon 1 pm 2 pm 3 pm 4 pm

### KS2 2008 Paper B level 3

- Compare the impact of representations where scales have intervals of differing step size

Examples of the same information represented on vertical axes with different scales

Number of gold medals in the 2000 Olympics shown on a bar chart with the vertical axis numbered in 20s from 0 to 100.

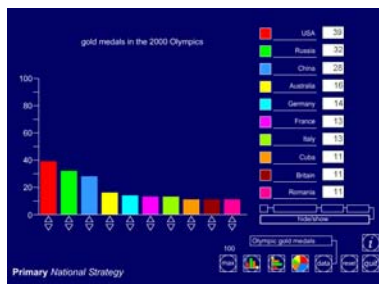

Number of gold medals in the 2000 Olympics shown on a bar chart with the vertical axis numbered in 10s from 0 to 40.

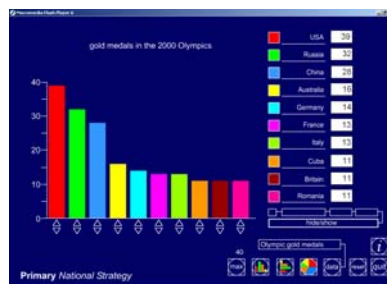

ITP Data handling

**Acknowledgment**

Questions from various QCA papers. © Qualifications and Curriculum Authority. Used with kind permission.

QCA test questions and mark schemes can be found at [www.testbase.co.uk](http://www.testbase.co.uk)