

Ma

KEY STAGE

3

TIER

6–8**2003**

Mathematics test

Paper 1

Calculator not allowed

Please read this page, but do not open your booklet until your teacher tells you to start. Write your name and the name of your school in the spaces below.

First name _____

Last name _____

School _____

Remember

- The test is 1 hour long.
- You **must not** use a calculator for any question in this test.
- You will need: pen, pencil, rubber and a ruler.
- Some formulae you might need are on page 2.
- This test starts with easier questions.
- Try to answer all the questions.
- Write all your answers and working on the test paper – do not use any rough paper. Marks may be awarded for working.
- Check your work carefully.
- Ask your teacher if you are not sure what to do.

For marker's
use only

Total marks	
-------------	--

Instructions

Answers



This means write down your answer or show your working and write down your answer.

Calculators



You **must not** use a calculator to answer any question in this test.

Formulae

You might need to use these formulae

Trapezium

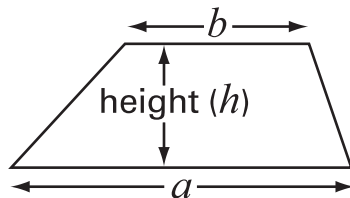

$$\text{Area} = \frac{1}{2}(a + b)h$$

Prism

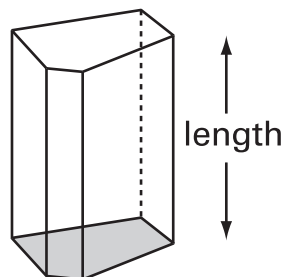

$$\text{Volume} = \text{area of cross-section} \times \text{length}$$

1. Solve these equations.

Show your working.



$$3t + 4 = t + 13$$

$$t = \dots\dots\dots$$

.....

.....
2 marks

$$2(3n + 7) = 8$$

$$n = \dots\dots\dots$$

.....
1 mark



2. The drawing shows how shapes A and B fit together to make a right-angled triangle.

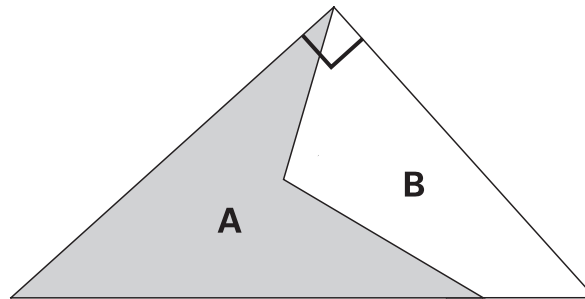

Work out the size of each of the angles in shape B.

Write them in the correct place in shape B below.

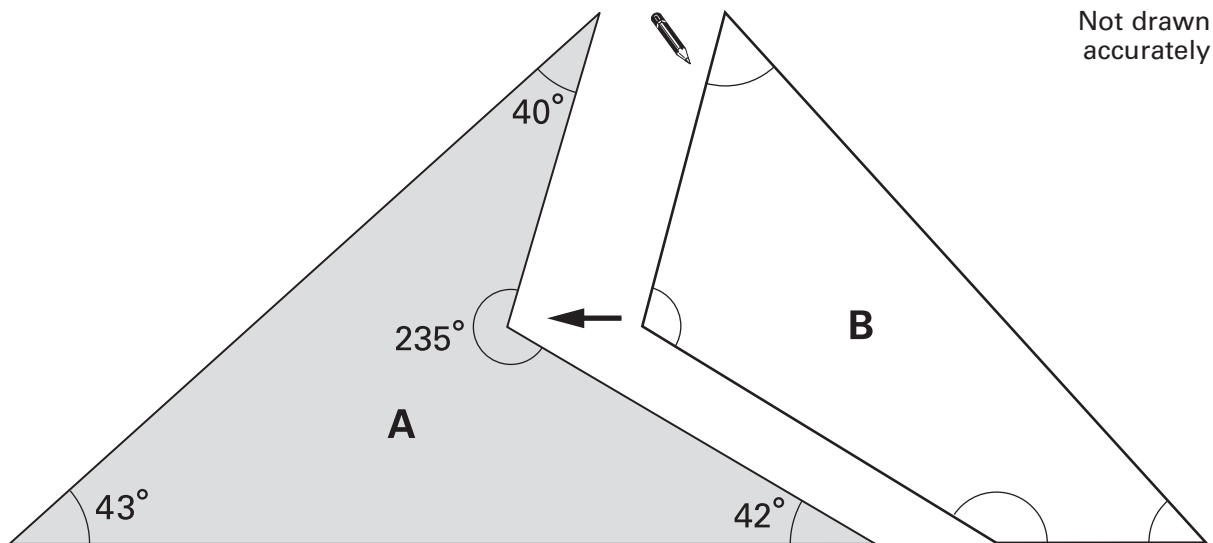

.....

 3 marks

3. (a) Add $\frac{6}{10}$ and $\frac{6}{5}$



.....

.....
1 mark

Now use an arrow (\downarrow) to show the result on the number line.

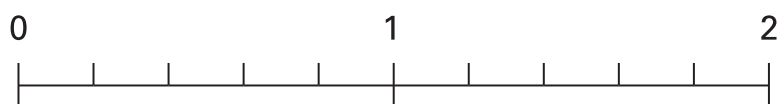

.....
1 mark

- (b) How many **sixths** are there in $3\frac{1}{3}$?



.....

.....
1 mark

- (c) Work out $3\frac{1}{3} \div \frac{5}{6}$

Show your working.



.....

.....
2 marks



4. (a) The diagram shows a rectangle.

Its dimensions are $3a$ by $5b$

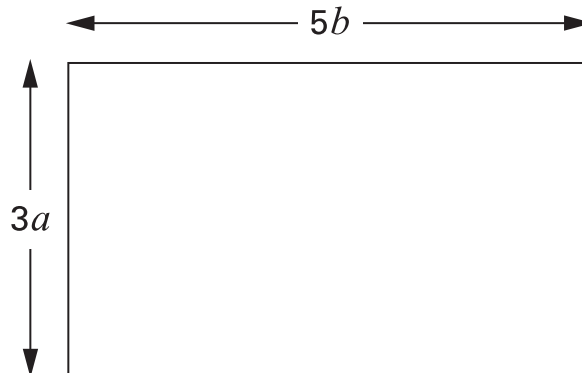

Write **simplified expressions** for the area and the perimeter of this rectangle.



Area:

.....
1 mark

Perimeter:

.....
1 mark

(b) A different rectangle has **area $12a^2$** and **perimeter $14a$**

What are the dimensions of this rectangle?



Dimensions: by

.....
1 mark

5. Here are six number cards.



(a) Arrange these six cards to make the calculations below.

The first one is done for you.

$$939 = \begin{array}{|c|c|c|} \hline 4 & 2 & 3 \\ \hline \end{array} + \begin{array}{|c|c|c|} \hline 5 & 1 & 6 \\ \hline \end{array}$$



$$1164 = \begin{array}{|c|c|c|} \hline & & \\ \hline \end{array} + \begin{array}{|c|c|c|} \hline & & \\ \hline \end{array}$$

1 mark

$$750 = \begin{array}{|c|c|c|} \hline & & \\ \hline \end{array} + \begin{array}{|c|c|c|} \hline & & \\ \hline \end{array}$$

1 mark

(b) Now arrange the six cards to make a **difference** of 115



$$115 = \begin{array}{|c|c|c|} \hline & & \\ \hline \end{array} - \begin{array}{|c|c|c|} \hline & & \\ \hline \end{array}$$

1 mark



6. The diagram shows a square drawn on a square grid.

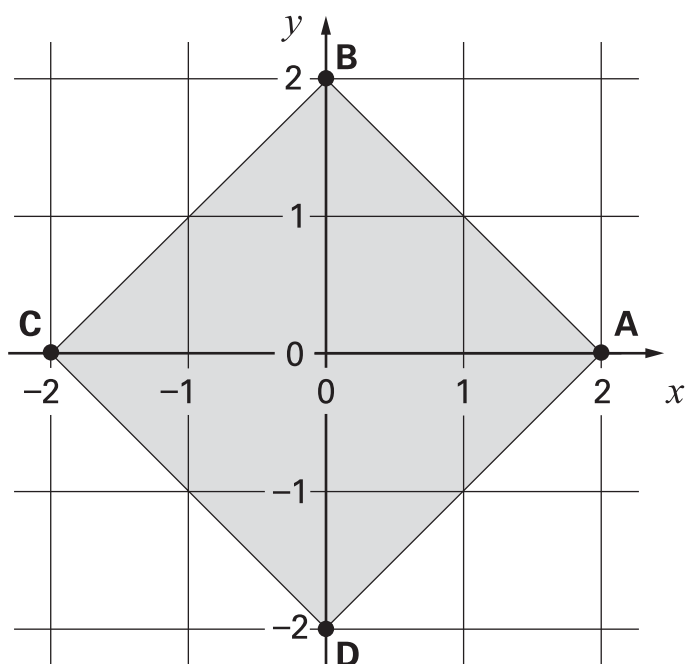

- (a) The points A, B, C and D are at the vertices of the square.

Match the correct line to each equation.

One is done for you.



$$y = 0$$

Line through C and D

Line through A and C

$$x = 0$$

Line through A and D

$$x + y = 2$$

Line through B and D

Line through B and C

$$x + y = -2$$

Line through A and B

.....

.....
2 marks

The mid-points of each side, E, F, G and H, join to make a different square.

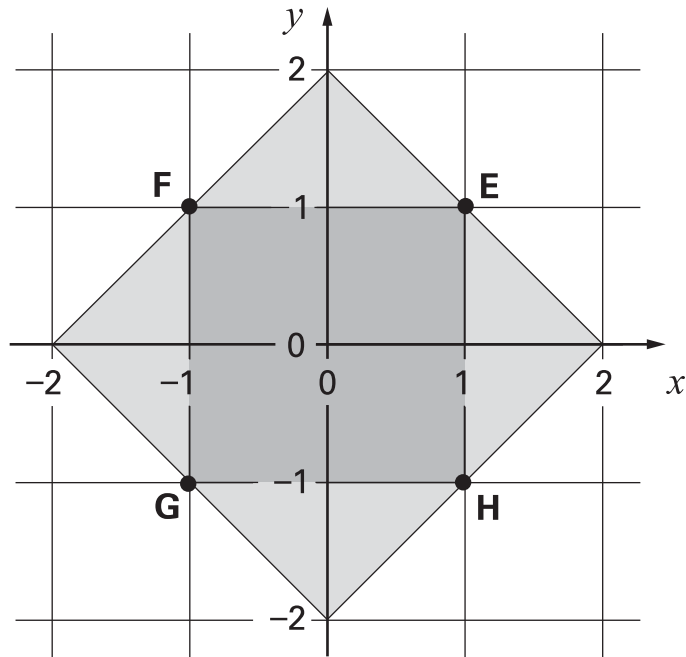

(b) Write the equation of the straight line through **E** and **H**.



.....
1 mark

(c) Is $y = -x$ the equation of the straight line through **E** and **G**?

Tick (✓) Yes or No.



Yes No

Explain how you know.



.....
1 mark



7. The scatter graph shows information about trees called poplars.

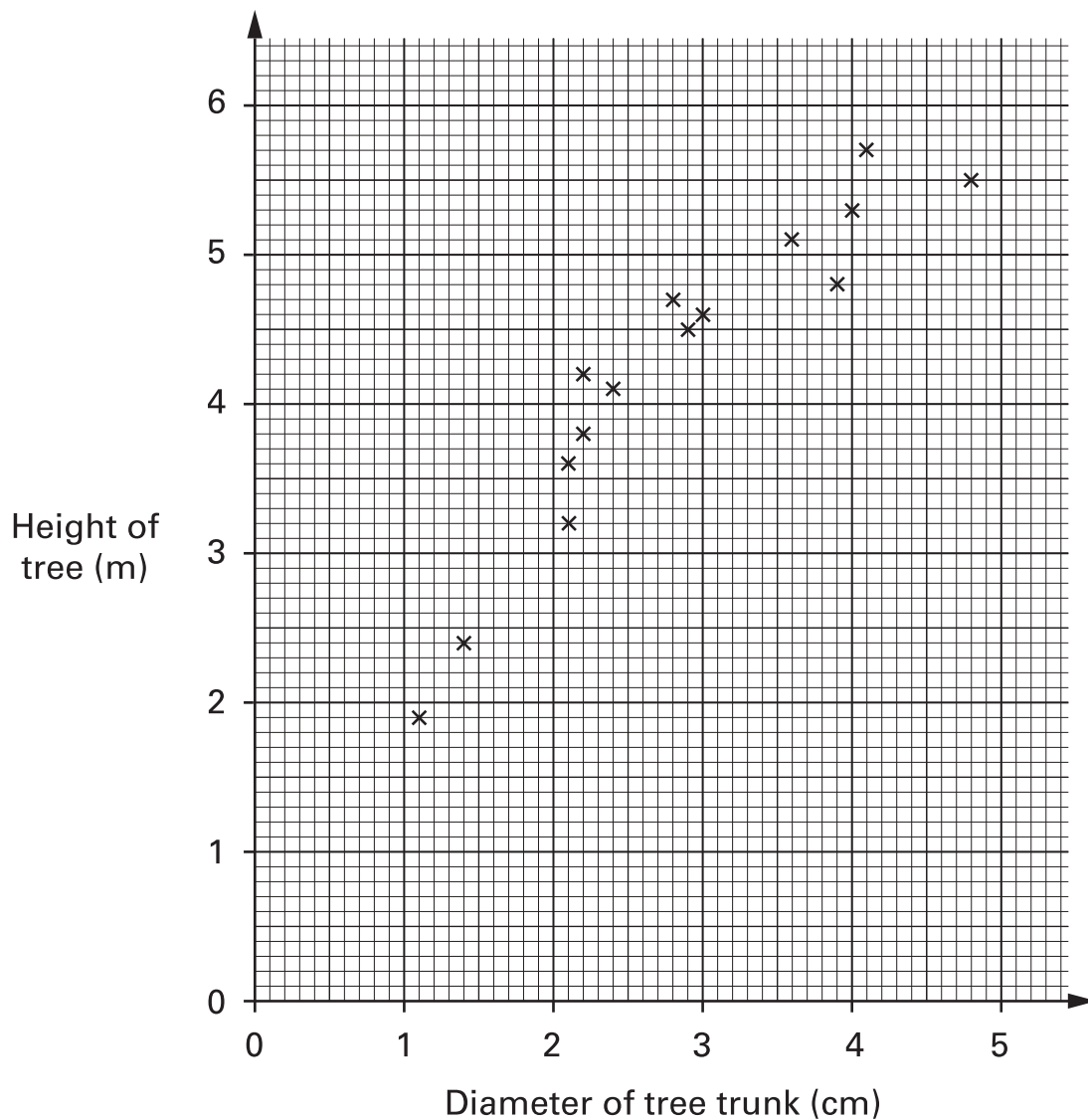

- (a) What does the scatter graph show about the **relationship** between the diameter of the tree trunk and the height of the tree?



- (b) The height of a different tree is 3m. The diameter of its trunk is 5cm.
Use the graph to explain why this tree is **not** likely to be a poplar.



.....
1 mark

- (c) Another tree **is** a poplar. The diameter of its trunk is 3.2 cm.
Estimate the height of this tree.



..... m

.....
1 mark

- (d) Below are some statements about drawing lines of best fit
on scatter graphs.

For each statement, tick (✓) to show whether the statement is True or False.

Lines of best fit must **always** ...



go through the origin.

True

False

have a positive gradient.

True

False

join the smallest and the largest values.

True

False

pass through every point on the graph.

True

False

.....

.....
2 marks



8. A headteacher wants to choose a pupil from year 7, 8 or 9 to appear on television.

The headteacher gives each pupil **one** ticket.

Then she will select the winning ticket at random.

The table shows information about the tickets used.

	Colour of the ticket	Numbers used
Year 7	red	1 to 80
Year 8	blue	1 to 75
Year 9	yellow	1 to 90

- (a) What is the probability that the winning ticket will be **blue**?



1 mark

- (b) What is the probability that the winning ticket will show number **39**?



1 mark

- (c) The headteacher selects the winning ticket at random.

She says:

'The winning ticket number is 39'.

What is the probability that this winning ticket is blue?



1 mark

9. The diagram shows the distance between my home, H, and two towns, A and B.

It also shows information about journey times.

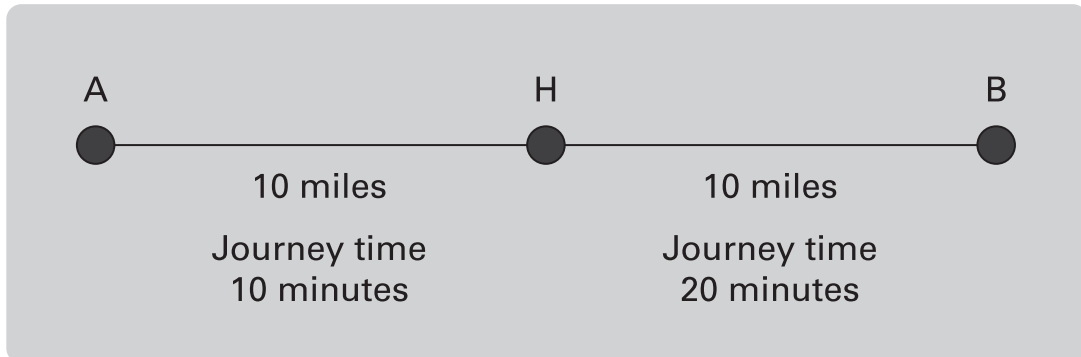

- (a) What is the average speed of the journey from my home to **town A**?



.....

.....
1 mark

- (b) What is the average speed of the journey from my home to **town B**?



.....

.....
1 mark

- (c) I drive from town A to my home and then to town B.

The journey time is 30 minutes.

What is my average speed?

Show your working.



.....
.....

.....
2 marks



10. (a) Pupils started to solve the equation $6x + 8 = 4x + 11$ in different ways.
For each statement below, tick (✓) True or False.



$$6x + 8 = 4x + 11$$

so $14x = 15x$

True False

$$6x + 8 = 4x + 11$$

so $6x + 4x = 11 + 8$

True False

$$6x + 8 = 4x + 11$$

so $6x = 4x + 3$

True False

$$6x + 8 = 4x + 11$$

so $2x + 8 = 11$

True False

$$6x + 8 = 4x + 11$$

so $2x = 3$

True False

$$6x + 8 = 4x + 11$$

so $-3 = -2x$

True False

.....
.....
.....
3 marks

- (b) A different pupil used trial and improvement to solve the equation $6x + 8 = 4x + 11$

Explain why trial and improvement is not a good method to use.



.....
1 mark

11. The diagram below shows two points A and B that are 6cm apart. Around each point are six circles of radius 1cm, 2cm, 3cm, 4cm, 5cm and 6cm. Each circle has either A or B as its centre.

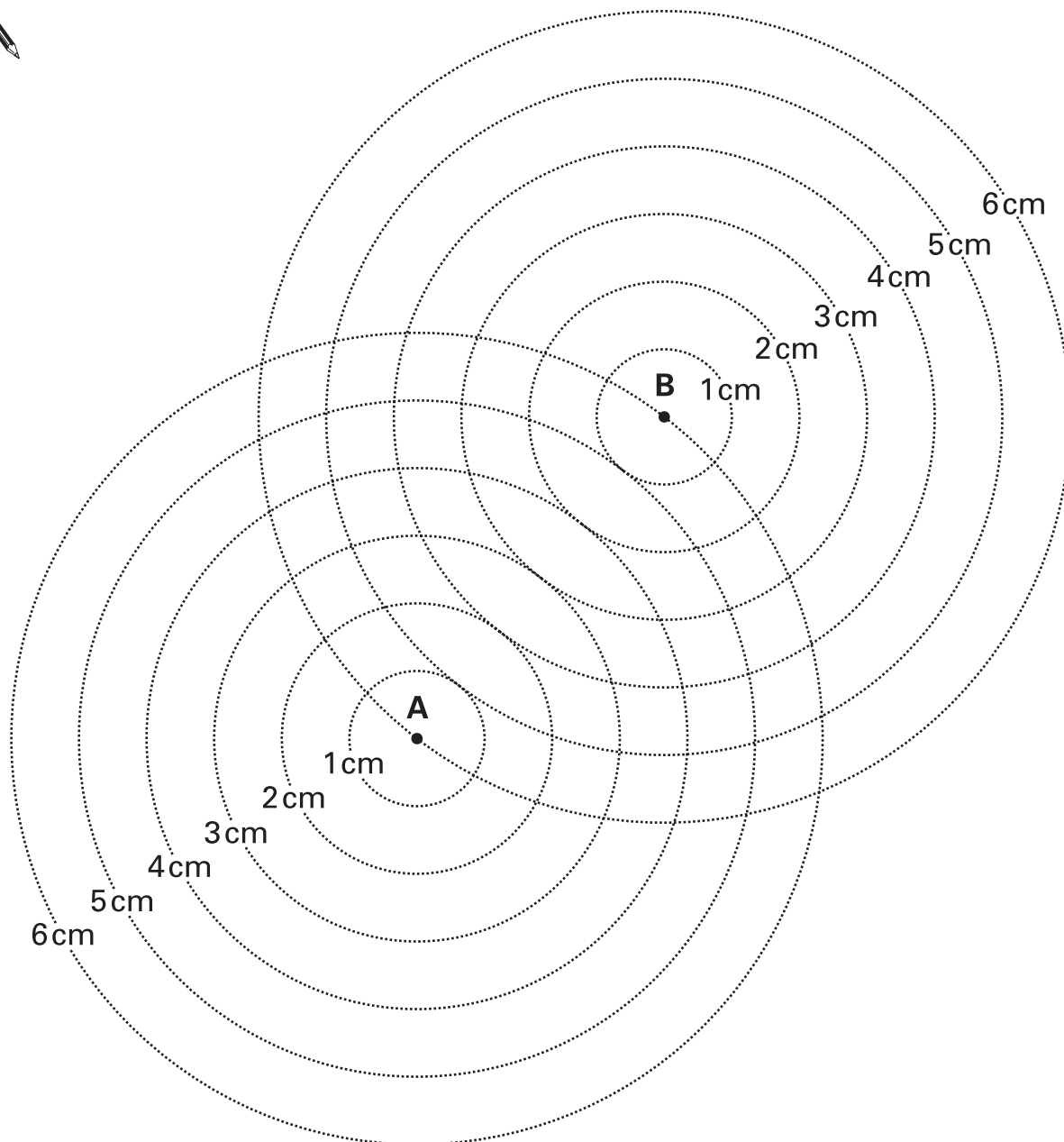

- (a) On the diagram, mark with a cross any points that are 4cm away from A **and** 4cm away from B.

.....
1 mark

- (b) Now draw the locus of **all** points that are the **same distance** from A as they are from B.

.....
1 mark



12. For each part of the question, tick (✓) the statement that is true.

(a)

When x is even,
 $(x - 2)^2$ is even

When x is even,
 $(x - 2)^2$ is odd



Show how you know it is true for **all** even values of x



1 mark

(b)

When x is even,
 $(x - 1)(x + 1)$ is even

When x is even,
 $(x - 1)(x + 1)$ is odd



Show how you know it is true for **all** even values of x



1 mark

13. Look at the graph.

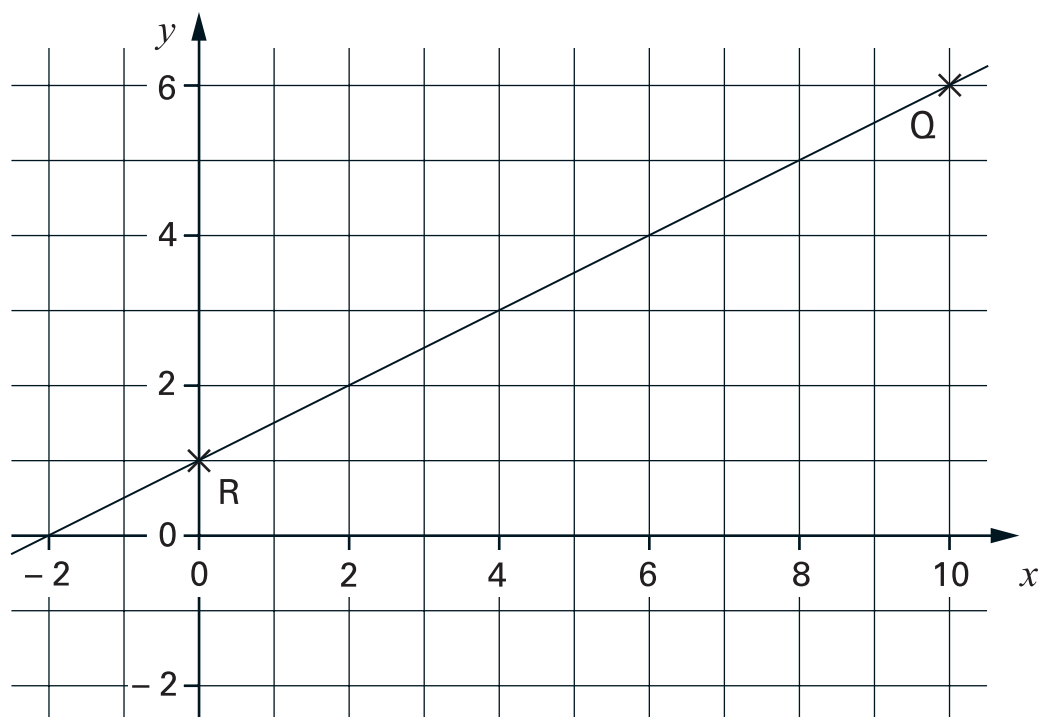

- (a) The **gradient** of the line through R and Q is **0.5**

Show how you can work this out from the graph.



.....
1 mark

- (b) What is the **equation** of the straight line through R and Q?



.....
.....
2 marks

- (c) Write the equation of a line that is **parallel** to the straight line through R and Q.



.....
1 mark



14. Tom did a survey of the age distribution of people at a theme park.
He asked **160 people**.

The cumulative frequency graph shows his results.

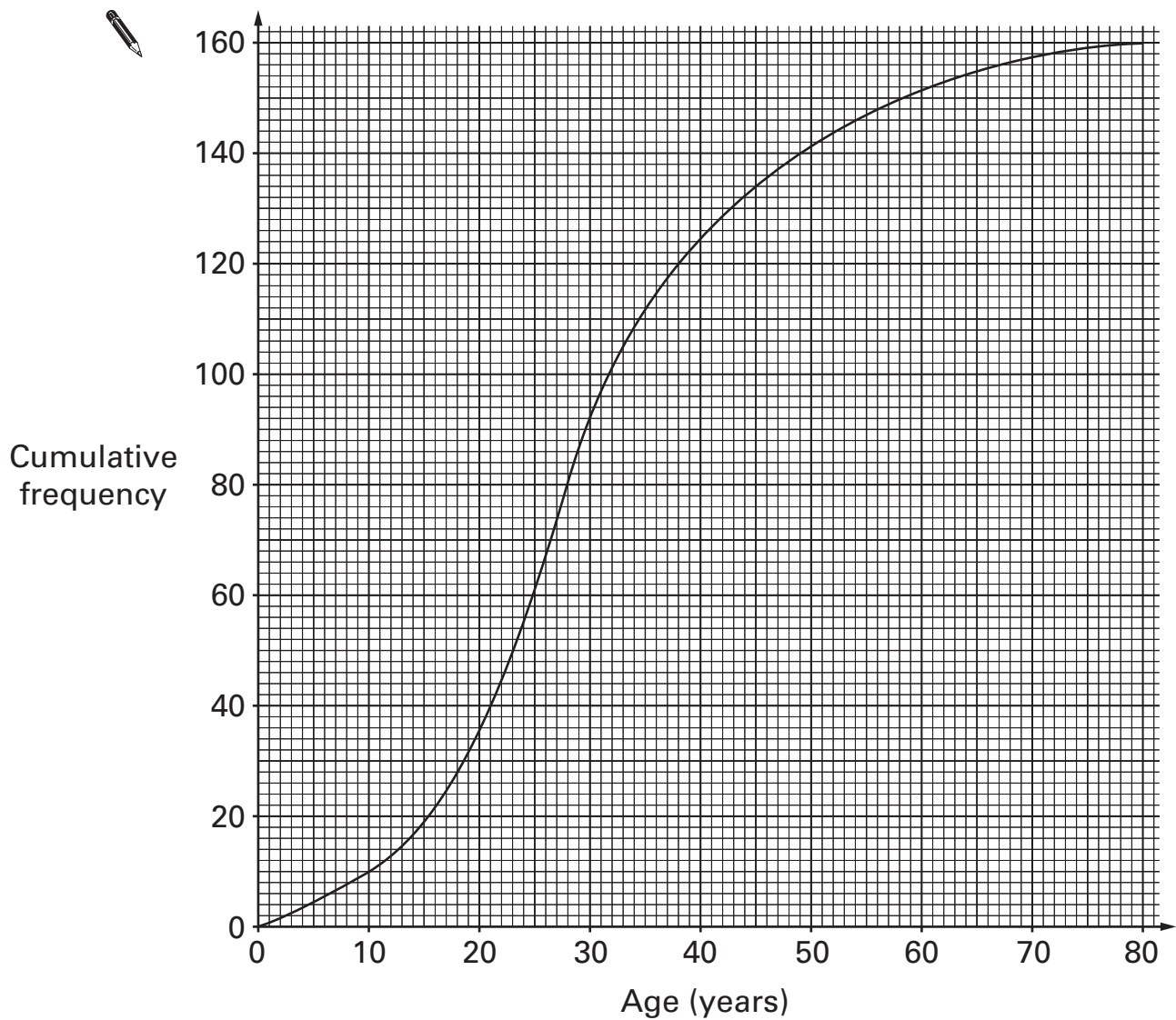

(a) Use the graph to estimate the **median** age of people at the theme park.



median = years

.....
1 mark

(b) Use the graph to estimate the **interquartile range** of the age of people at the theme park.

Show your method on the graph.



interquartile range = years

.....
.....
2 marks

(c) Tom did a similar survey at a flower show.

Results:

The **median** age was **47 years**.

The **interquartile range** was **29 years**.

Compare the age distribution of the people at the flower show with that of the people at the theme park.



.....
1 mark



15. (a) Solve these inequalities.

Show your working.

$$\frac{2(2y + 7)}{3} < 2$$



.....

.....
2 marks

$$\frac{4(7 - 2y)}{12} > 1$$



.....

.....
2 marks

(b) Kate is solving the inequality $y^2 < 9$

She says:

$y^2 < 9$ **whenever** y is less than 3'

Kate is **not** correct. Explain why.



.....
1 mark

16. The diagram shows 3 points, A, B and C, on a circle, centre O.
AC is a diameter of the circle.

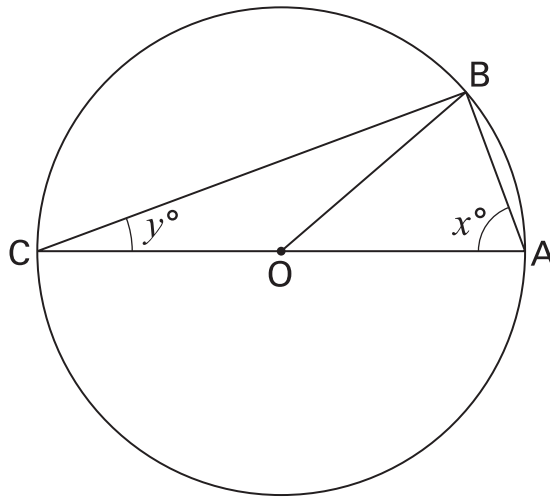

- (a) Angle BAO is x° and angle BCO is y°

Explain why angle ABO must be x° and angle CBO must be y°



.....
1 mark

- (b) Use algebra to show that angle ABC **must** be 90°



.....
1 mark



17. A girl plays the same computer game lots of times.
 The computer scores each game using **1 for win, 0 for lose**.
 After each game, the computer calculates her **overall mean score**.
 The graph shows the results for the first **20 games**.

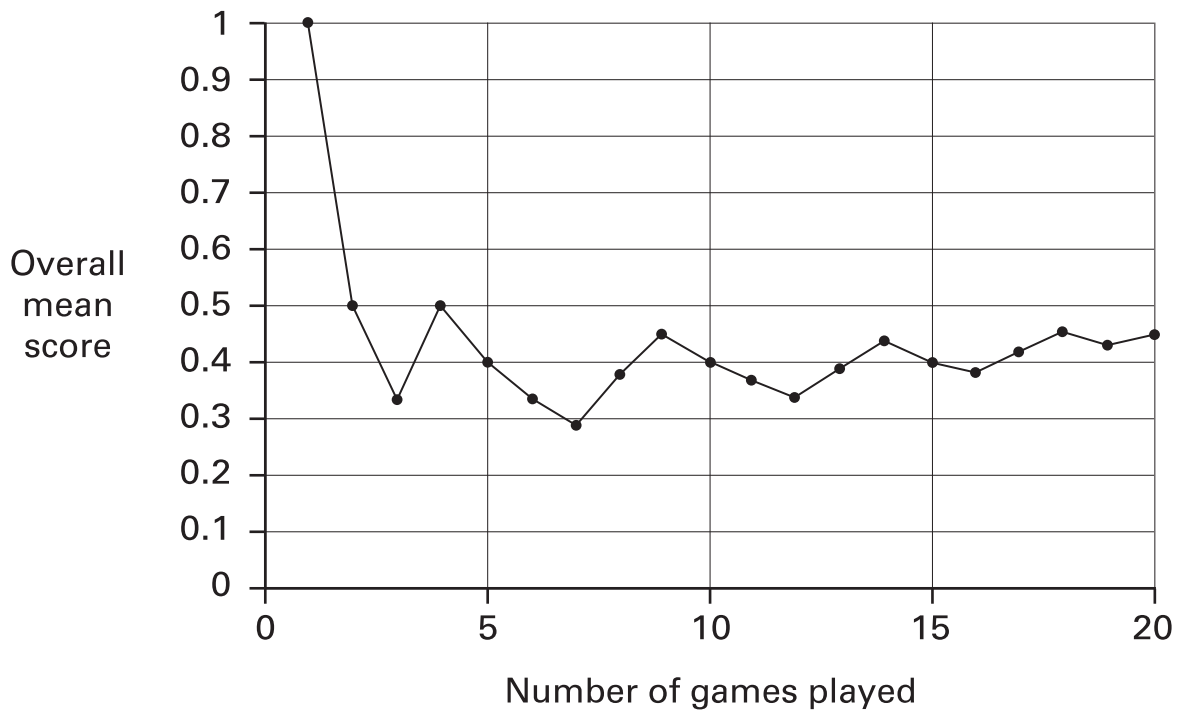

- (a) For each of the **first 3** games, write W if she won or L if she lost.



first game second game third game
 1 mark

- (b) What percentage of the 20 games did the girl win?



..... %
 1 mark

The graph below shows the girl's results for the first 100 games.

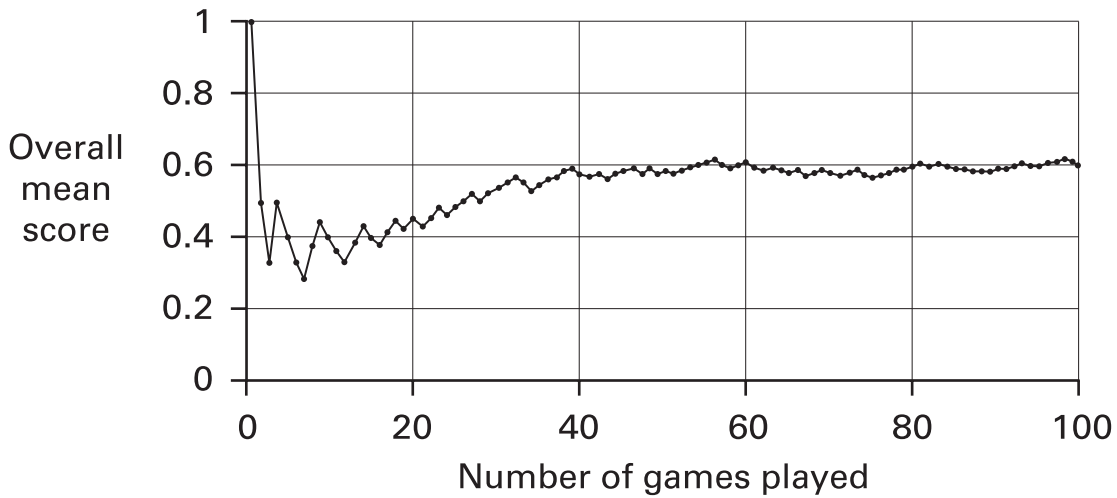

(c) She is going to play the game again.

Estimate the probability that she will win.



1 mark

(d) Suppose for the 101st to 120th games, the girl were to **lose each game**.

What would the graph look like up to the 120th game?

Show your answer on the graph below.

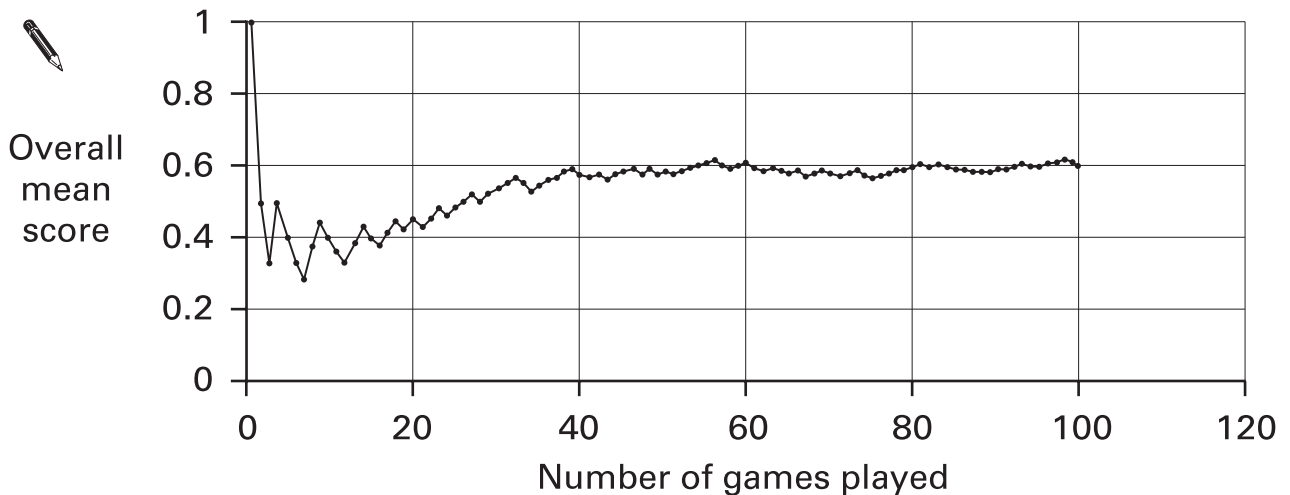

1 mark



END OF TEST