

Sc

KEY STAGE
3TIER
5–7

2005

Science test

Paper 2

Please read this page, but do not open the booklet until your teacher tells you to start. Write your name and the name of your school in the spaces below.

First name _____

Last name _____

School _____

Remember

- The test is 1 hour long.
- You will need: pen, pencil, rubber, ruler, protractor and calculator.
- The test starts with easier questions.
- Try to answer all of the questions.
- The number of marks available for each question is given below the mark boxes in the margin. You should not write in this margin.
- If you are asked to plan an investigation, there will be space for you to write down your thoughts and ideas.
- Do not use any rough paper.
- Check your work carefully.
- Ask your teacher if you are not sure what to do.

For marker's
use only

Total marks	
Borderline check	

1. The drawing below shows a garden water feature. It is solar-powered.

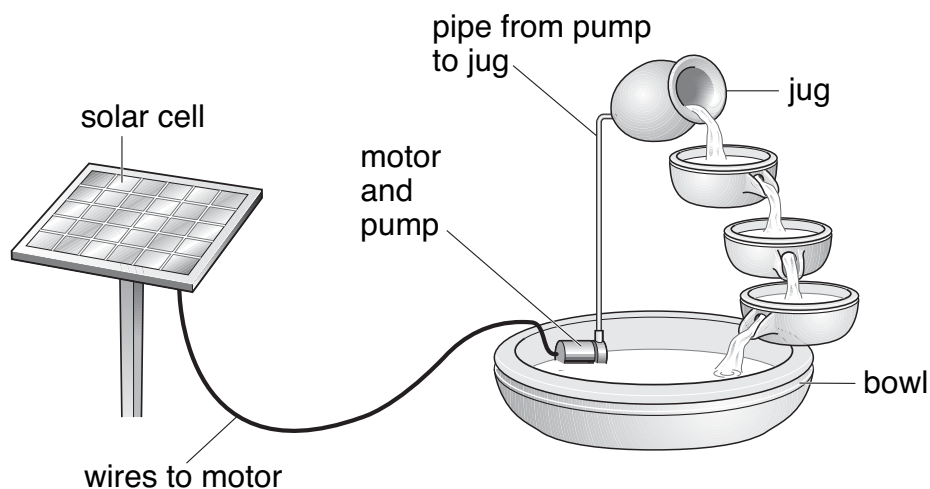

The solar cell absorbs energy from the Sun.
 The solar cell is connected to a motor in the bowl.
 The motor drives a pump.
 Water is pumped up to the jug and it flows back down to the bowl.

- (a) Use the information above to help you to complete the following sentences.
 Choose words from the list.

chemical

electrical

gravitational
potential

kinetic

light

sound

thermal

- (i) The useful energy change in the solar cell is from
 light to _____ energy.
- (ii) The useful energy change in the motor is from
 electrical energy to _____ energy.
- (iii) As the water flows from the jug to the bowl _____
 energy is changed into _____ energy.

1ai

1 mark

1aii

1 mark

1aiii

1 mark

1aiii

1 mark

(b) Give **one** advantage and **one** disadvantage of using a solar cell to power the water feature.

advantage _____

disadvantage _____

1b
1 mark

1b
1 mark

maximum 6 marks

2. Lorna built the circuit drawn below. All the bulbs are identical.

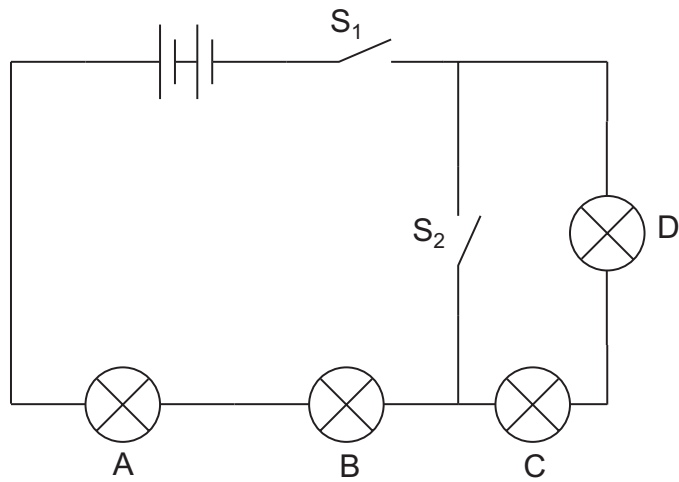

(a) Complete the table below by writing **on** or **off** for each bulb. One has been done for you.

switch		bulb			
S_1	S_2	A	B	C	D
open	open	off	off	off	off
open	closed				
closed	open				
closed	closed				

2a
1 mark

2a
1 mark

2a
1 mark

(b) Lorna then built a different circuit as shown below.

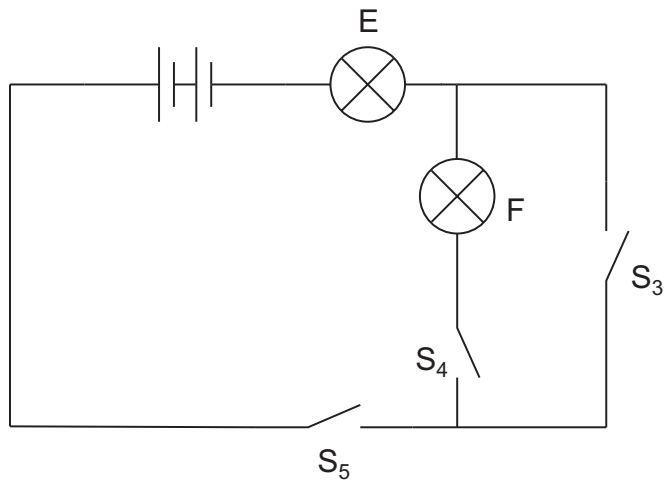

How could Lorna get both bulbs to light at the same time in this circuit?

1 mark

maximum 4 marks

3. (a) (i) Air contains nitrogen.
In the box below draw **five** circles, ○, to show the arrangement of particles in nitrogen gas.

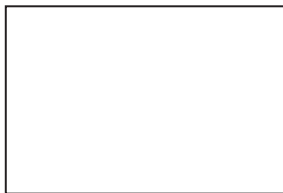

3ai

1 mark

- (ii) Zeena carries a personal emergency alarm.
It uses nitrogen gas to produce a very loud sound.

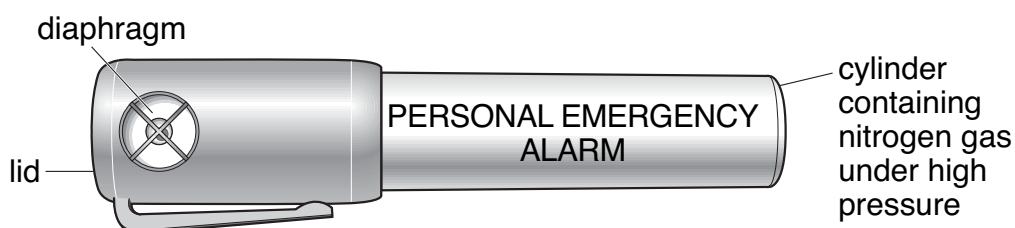

The nitrogen gas in the container is under much higher pressure than the nitrogen gas in the air.

How does the arrangement of nitrogen particles change when the gas is under higher pressure?



3aii

1 mark

- (b) Use words from the boxes below to complete the sentence.

greater than

less than

the same as

The rate at which the nitrogen particles hit the inside of the container is _____ the rate at which nitrogen particles hit the outside of the container.



3b

1 mark

- (c) Zeena pushes the lid down and nitrogen gas escapes through the diaphragm.
The diaphragm vibrates and produces a sound.

The pattern on the oscilloscope screen below represents the soundwave produced by the alarm.

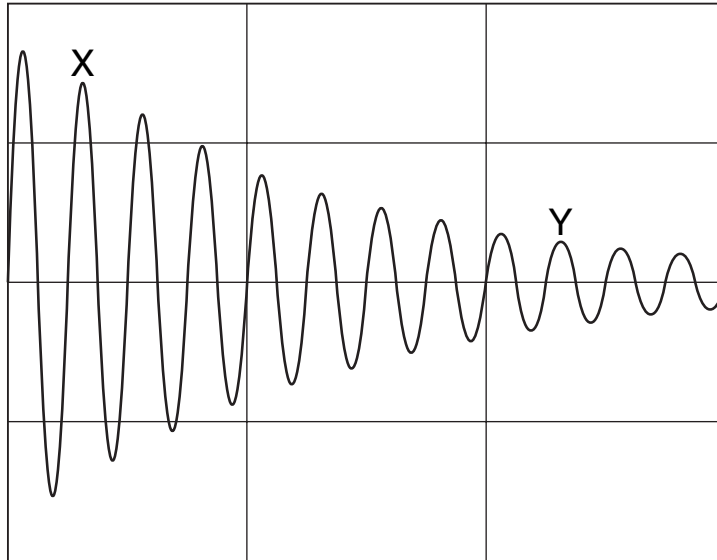

- (i) The loudness of the sound produced by the alarm decreases between X and Y.

How can you tell this from the graph?

1 mark

- (ii) The pitch of the sound produced by the alarm stays the same between X and Y.

How can you tell this from the graph?

1 mark

maximum 5 marks

4. Molly used a pH sensor to test different liquids. She dipped the probe of the sensor into each liquid and recorded the pH value in a table.

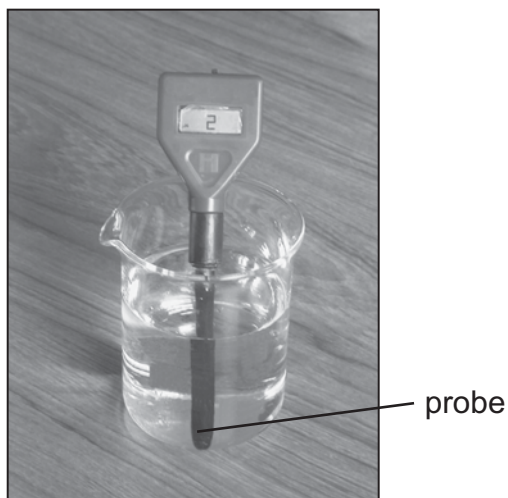

- (a) In the table below, tick **one** box for each liquid to show whether it is **acidic**, **neutral** or **alkaline**. One has been done for you.

liquid	pH value	acidic	neutral	alkaline
alcohol	7			
dilute hydrochloric acid	2	✓		
distilled water	7			
vinegar	3			
sodium hydroxide solution	11			

4a

1 mark

4a

1 mark

- (b) Between each test Molly dipped the probe into distilled water.

- (i) Why did she do this?

4bi

1 mark

- (ii) Which other liquid in the table could Molly use between tests to have the same effect as distilled water?

4bii

1 mark

- (c) Molly put a piece of magnesium into a test-tube containing 20 cm³ of vinegar. She put another piece of magnesium into a test-tube containing 20 cm³ of dilute hydrochloric acid.

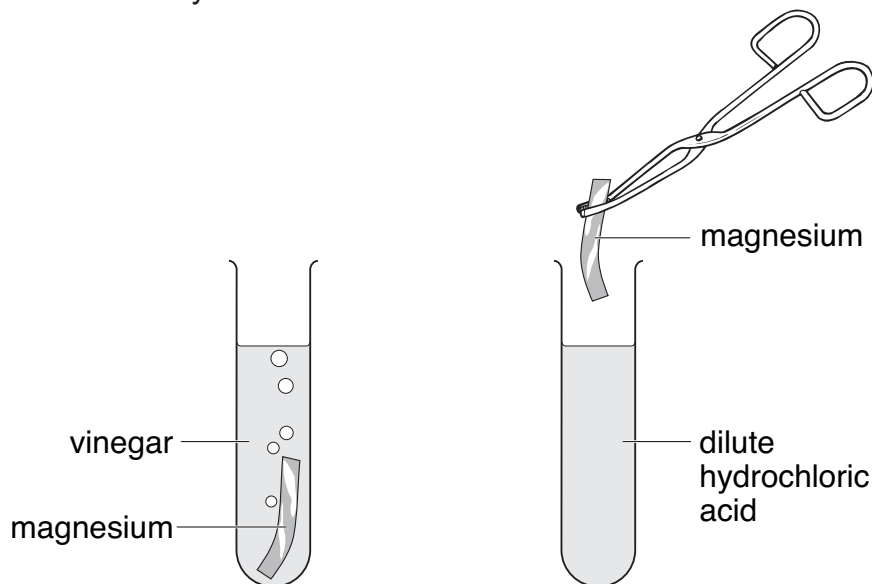

- (i) Molly thought that magnesium would react more vigorously with hydrochloric acid than with vinegar. What information in the table made Molly think this?

4ci
1 mark

- (ii) How would Molly be able to tell if a more vigorous reaction took place with hydrochloric acid than with vinegar?

4cii
1 mark

- (d) (i) Complete the word equation for the reaction between magnesium and hydrochloric acid.

magnesium + hydrochloric acid → _____ + _____

4di
1 mark

4di
1 mark

- (ii) After some time this reaction stopped. Why did the reaction stop?

4dii
1 mark

maximum 9 marks

5. Two groups of pupils investigated the factors affecting the time taken for an indigestion tablet to dissolve in 100 cm³ of water.



Group 1 recorded their results in the table below.

results of group 1

tablet	time taken to dissolve (s)
whole tablet	34
broken tablet	28
finely crushed tablet	22

- (a) What factor did group 1 change as they carried out their investigation?



5a

1 mark

- (b) Before the investigation, group 1 made a prediction.
They found this prediction was supported by the results in the table.

What prediction did group 1 make?



5b

1 mark

- (c) Group 2 investigated how the temperature of the water affects the time taken for a whole tablet to dissolve.

Here are their results.

results of group 2

temperature of water (°C)	time taken to dissolve (s)
65	24
40	35
15	90
5	100

What factor did group 2 change as they carried out their investigation?

5c
1 mark

- (d) What pattern do the results recorded by group 2 show?

5d
1 mark

- (e) Look at the results presented by group 1 and group 2.
Both groups used the same type of tablet.

Estimate the temperature of water used by group 1.

_____ °C

5e
1 mark

maximum 5 marks

6. (a) When fertilisation takes place, the nucleus of a sperm joins with the nucleus of an ovum (egg).

In which part of the reproductive system does fertilisation normally take place in humans?

Tick the correct box.

cervix	<input type="checkbox"/>	ovary	<input type="checkbox"/>
oviduct	<input type="checkbox"/>	uterus	<input type="checkbox"/>

6a

1 mark

- (b) The table below gives information about fertilisation in three animals.

animal	Does fertilisation take place inside or outside the body?	number of eggs released at a time
human	inside	1
bird	inside	4
frog	outside	3000

Frogs release their eggs and sperm into water.

The eggs are fertilised in the water.

Why is it an advantage for frogs to release large numbers of eggs and sperm?

6b

1 mark

- (c) The diagram shows a section through a fertilised egg of a bird.

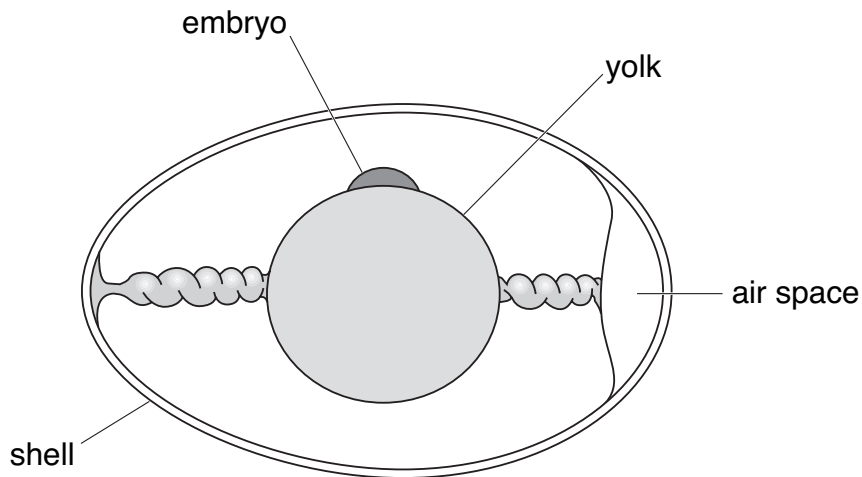

- (i) The shell of a bird's egg is porous. This means it has microscopic holes in it.

Why does it need to be porous?

6ci
1 mark

- (ii) Give **one** other function of the egg shell.

6cii
1 mark

- (d) A bird's egg contains yolk which is a food store for the developing chick. A human egg does **not** contain yolk.

Why does a human egg **not** need to contain a food store for the embryo?

6d
1 mark

maximum 5 marks

7. (a) The diagram shows a group of cells from the lining of the mouth.

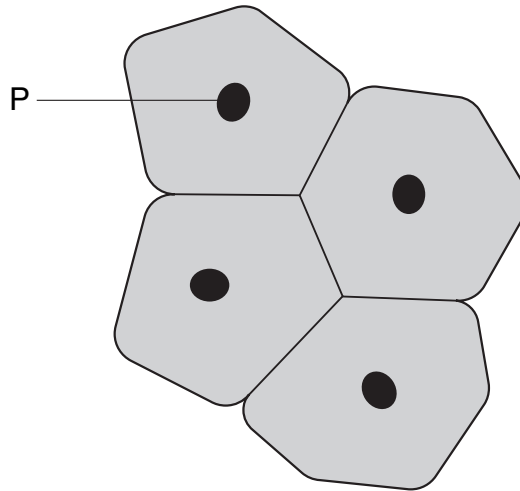

- (i) Give the name and function of part P.

name of part P

function of part P

- (ii) Which word describes this group of cells?
Tick the correct box.

compound

organism

organ

tissue

7ai

1 mark

7ai

1 mark

7aii

1 mark